

COMET[®]

WINDMILL & WATER PRODUCTS

2016

CUSTOMER

PRICE CATALOGUE

valid August 2016

- Windmills
- Tank Stands
- Pumps
- Troughs



Ph: 02 6568 3711 Fax: 02 6568 3722

TABLE OF CONTENTS

1. Warranty.....	3
2. Pump Table.....	4
3. Selection Guide.....	6-7
4. C & D Pattern Windmills... ..	8
5. Windmill Pumps... ..	10
6. Packing Tubes... ..	11
7. Pump Buckets.	12
8. Tank Stands.....	13
9. Floats.....	14
10. Wheel Assembly... ..	15
11. Overhaul Kits C Pattern.....	16
12. Parts Illustration C Pattern.....	17-18
13. Overhaul Kits D Pattern	19
14. Parts Illustration D Pattern.	20-26
16. Mill Rods & Connections.....	31
17. Pump Rods & Connections... ..	31-33
18. Clamps... ..	34

Disclaimer: Prices quoted are exclusive of GST and Freight.

Prices are correct at the time of printing but are subject to change without notice. Comet Windmills Australia will endeavour to send out new price sheets of products that change in price to include in your pricebook. If you are unsure or if you require large quantities we are more than happy to provide a special quote for your needs.

1 YEAR WARRANTY

COMET®
WINDMILL PRODUCTS

GUARANTEE AND WARRANTY TERMS

COMET WINDMILLS—ONE (1) YEAR

This conditional guarantee is valid only if the following details are adhered to. All parts received are to be checked off and accounted for within 7 days of receipt. Any claims for missing or damaged parts are to be notified within 7 days. Accounts are to be paid in full within 30 days from the date of the Tax Invoice supplied from Comet unless otherwise negotiated. Comet Windmills Australia is not responsible for the erection or installation of the mill, bore, pump or spare parts. The company manufactures and supplies genuine Comet Parts only. Comet will recommend an installer or mechanic only, but it is the responsibility of the Buyer to make the arrangements, pay for costs involved with erection/installation and ensure products are erected in accordance with manufacturers instructions. Comet Products are supplied based on the information given. The Buyer must also ensure that the manufacturers instructions are followed and that the parts are stored in a manner that will not cause the parts to rust, erode, wear or be damaged if not erected when received. This guarantee will be voided if non-Genuine parts have been used or any alterations, modifications, welding or machining has been done to original parts or on parts used to replace genuine parts.

All Comet Windmill Genuine Parts have a conditional One (1) year warranty. The company guarantees that the Comet Windmill will do all that it claims provided the pumping and wind conditions are in accordance with those specified on the Comet Pumping Table; it is properly erected on a Comet Tower in the manner described in the company's Erecting Instructions on foundations which in the Company's opinion are satisfactory; and that oiling, adjustments and maintenance have been properly attended to according to the Company's recommendations. Comet Windmills Australia only supplies products based on the information that has been supplied by the Buyer. It holds no responsibility for incorrect information or incorrect site details supplied. The company will endeavour to obtain as much information as necessary for it to identify the most suitable equipment and size.

Comet will repair or replace at its discretion any defective parts of the windmill which the company has been notified of within the 1 year period from the date of purchase provided prior approval by an authorised staff member. The defective part must be returned for inspection with all transport and other charges pre-paid.

This guarantee shall be modified if the windmill is not protected from the weather before erection and if it is not erected within three (3) months from the original date of despatch by the company. In such cases it would be necessary for special arrangements to be made with the company at its discretion.

OTHER COMET PRODUCTS—ONE (1) YEAR

All other standard Comet products are guaranteed under the same conditions as are Comet Windmills, excepting that the free supply period and the time for lodgement of claim is ONE YEAR. *These guarantees shall not extend to cover labour and other costs incurred without the company's authority, damage caused by transport to site, consequential damage, damage caused by negligence, alteration or misuse, damage caused by fire, flood, storm surge, the action of sea, tidal wave, high water or tsunami, war or warlike activity, lawful destruction, erosion, damage, loss or injury that you or anyone acting for you deliberately caused, loss, damage or liability that does not occur within the period of warranty cover.*

Conditions

The warranty does not cover alteration, improper installation, misuse, abuse or neglect on the part of the owner or installer. Warranty is also invalid in any case that the product is altered, modified or installed with non genuine parts—ensure your warranty is registered and valid by filling out your warranty registration on the following page and return to Comet Windmills Australia, PO Box 340, Macksville, NSW 2447. Do not return without speaking to a staff member first. Non return will void your warranty.

WARRANTY ONLY APPLIES TO GENUINE COMET PARTS WITH PROOF OF PURCHASE.

PUMPING TABLE

After numerous pumping tests against other makes of mills, the founders, Sidney Williams & Co, were so confident about the superiority of the Comet that in 1934 they published a challenge, which has never been accepted over 125 years. The challenge was:

'Install a Comet and any other standard mill of the same size adjacent to it so that both mills work under identical pumping and wind conditions and if, after a period of three months trial, the Comet does not pump at least 25% more water we will remove it at no cost to you.'

The pumping capacities of Comet Mills, shown in the Table, are based on the number of pumping strokes (total inches) in 12-14 k.m.p.h winds blowing an average 24 hours and **also allow for slip/friction**. However, the pump sizes and elevations are such that with balanced pump rods and free pressure sealing devices the mills will start pumping in light breezes of under 8 m.p.h. (12.8 k.m.p.h).

PUMP SIZE Inches mm	8ft 2.44m		10ft 3.05m		12ft 3.66m		14ft 4.27m		16ft 4.88m		18ft 5.49m		20ft 6.10m		22ft 6.71ft		24ft 7.32m		27ft 8.23ft		30ft 9.14m	
	Ft Mt	gal L	Ft Mt	gal L	Ft Mt	gal L	Ft Mt	gal L	Ft Mt	gal L	Ft Mt	gal L	Ft Mt	gal L	Ft Mt	gal L	Ft Mt	gal L	Ft Mt	gal L	Ft Mt	gal L
1¼ 44	95 29	800 3640	160 49	850 3860	220 67	870 3960	310 95	960 4360														
2 50	75 22	1060 4820	130 40	1120 5090	175 53	1130 5140	250 76	1260 5730	320 98	1800 8180	410 125	1360 7410										
2¼ 57	60 18	1340 6090	105 32	1420 6460	140 43	1430 6500	200 61	1590 7230	265 81	2290 10410	350 107	2070 9410	480 146	2300 10460								
2½ 65	52 16	1650 7500	85 26	1750 7960	120 37	1770 8050	170 52	1960 8910	220 67	2830 12870	300 91	2550 11590	415 126	2850 12960	500 152	2550 11590	650 198	2830 12870				
2¾ 70	45 14	2000 9090	72 22	2130 9680	100 31	2150 9770	140 43	2380 10820	190 58	3430 15590	250 76	3100 14090	360 110	3450 15680	430 131	3100 14090	570 174	3430 15590	715 218	3800 17280	985 300	3360 15280
3 80	38 12	2380 10820	60 18	2500 11370	85 26	2550 11590	120 37	2830 12870	160 49	4080 18550	210 64	3680 16730	305 93	4100 18640	380 116	3680 16730	490 149	4080 18550	620 189	4350 19780	840 256	3950 17960
3¼ 83	32 10	2800 12730	50 15	2950 13410	72 22	3000 13640	105 32	3300 15000	135 41	4780 21730	180 55	4300 19550	260 79	4800 21820	325 99	4300 19550	430 131	4780 21730	520 158	5100 23190	650 198	4650 21140
3½ 90	28 9	3250 14780	45 14	3450 15680	63 19	3450 15680	90 27	3850 17500	118 36	5550 25230	155 47	5000 22730	225 69	5600 25460	280 85	5000 22730	370 113	5550 25230	470 143	5900 26820	570 174	5400 24550
4 100	22 7	4200 19090	35 11	4200 24090	78 24	5600 25460	116 35	6100 27730	162 49	8400 38190	216 66	7530 34230	298 91	8820 40100	350 107	8250 37510	445 136	9100 41370	613 187	9100 41370	775 236	8260 37550
4¼ 108	31 10	5750 26140	51 16	5950 27050	70 21	6300 28640	103 31	6800 30910	143 44	9500 43190	192 59	8450 38410	264 81	10000 45460	317 97	9330 42410	397 121	10350 47050	555 169	10250 46600	715 218	9320 42370
4½ 114	25 8	6450 29320	46 14	6650 30230	61 19	7100 32280	91 28	7700 35000	128 39	10700 48640	165 50	9550 43190	231 70	11200 50920	269 82	10400 47280	350 107	11500 52280	490 149	11400 51830	634 193	10450 47510
5 127	21 6	7500 34100	38 12	8250 37510	49 15	8700 39550	75 23	9500 43190	103 31	13200 60000	130 40	11750 53420	168 51	13750 62510	214 65	12850 58420	278 85	14200 64550	392 120	14200 64550	503 153	12900 58640
6 152	15 5	10500 47730	27 8	11500 52280	33 10	12600 57280	50 15	13700 62280	69 21	19000 86370	87 27	16900 76830	116 35	19800 90010	151 46	18500 84100	191 58	20550 93420	265 81	20400 92740	359 109	18550 84330
7 178			18 6	1550 70460	25 8	17050 77510	35 11	19750 89780	48 15	25650 116610	65 20	23000 104560	85 26	26300 119560	90 28	31500 143200	143 44	28000 127290	198 60	27800 126380	160 79	25300 115010
8 200					18 6	22400 101830	27 8	25650 116610	36 11	33850 153880	50 15	29900 135930	65 20	34000 154560	70 21	40300 183200	110 34	35900 163200	150 46	36400 165480	200 61	32800 149110

How to Use: Select the amount of water you want pumped on a daily basis in the highlighted column and/or the total head measurement and match to the closest value.

This Table is based on the minimum quantities guaranteed in normal light wind conditions over a 24 hour day. Comet mills will start turning in breezes lighter than 8 m.p.h (12.8 k.m.p.h). The pump sizes, elevations and capacities in this Table would be greater if they were based on the mills starting in stronger winds, as are generally the tables for other mills. The reason is that the starting torque of the wheel varies roughly as the square of wind speed; thus a 14 m.p.h (22 k.m.p.h) wind should develop four times as much torque as a 7 m.p.h (11 k.m.p.h) breeze.

Also, the higher daily capacities stated in other tables are obviously calculated on stronger winds of longer duration and shorter distances. The wind conditions for the Comet Table are more usual and therefore preferable.

The notes on The Selection Guide should be read before making use of the Comet Pumping Table. The Comet Pumping Table is a Guide only.

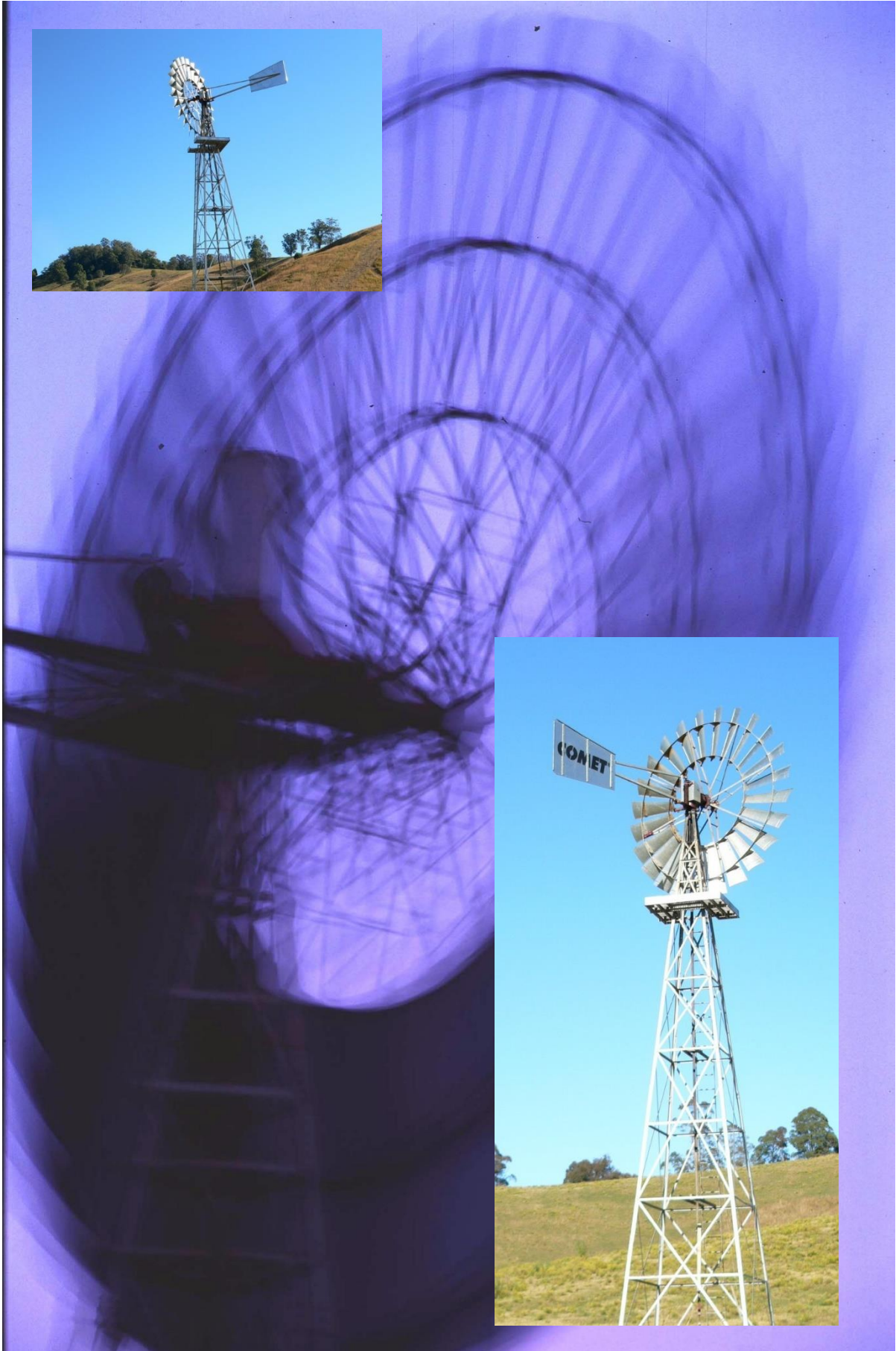

*Your first cost is your last cost with a Comet.
Quality is always remembered long after the price is forgotten.*

SELECTION GUIDE

Particulars Required For Design & Installation

INSTRUCTIONS

It is very important that you provide as much information as possible and supply accurate measurements so that the most efficient and least expensive pumping plant can be recommended to suit your requirements.

First choose the diagram that is most similar to your proposed site and pumping conditions. Answer the general data questions with accurate measurements and include pumping details. If you need a Mill Head only then refer to pages overleaf on Comet Mill Heads on Southern Cross Towers/3-Post Towers.

Photocopy this page to record your details and measurements.

Winds—The Winds, especially the light breezes, must have free access to the mill from all directions. The bottom of the wheel must be at least 15ft (14 metres) above all wind obstructions within 150yds (137 metres) of the mill. Comet pumping capacities are based on average medium winds of 12 to 14 m.p.h (19–22 k.m.p.h) blowing for 10 hours daily.

Elevations—The mill should be loaded and balanced so that it will start pumping in light breezes. Its size depends upon the size of the pump and total elevation. The latter includes not only the vertical heights for suction and delivery elevations but also an allowance for probable water flow friction in pipeline. The delivery pipe size should be at least half the pump diameter.

Suction—In a bore or well it is best to submerge the pump. For a creek or dam the pump should be placed close to the water and the suction elevation must not exceed 22ft (7m), or less if the suction pipeline is long.

COMET MILL PLANT DIAGRAMS

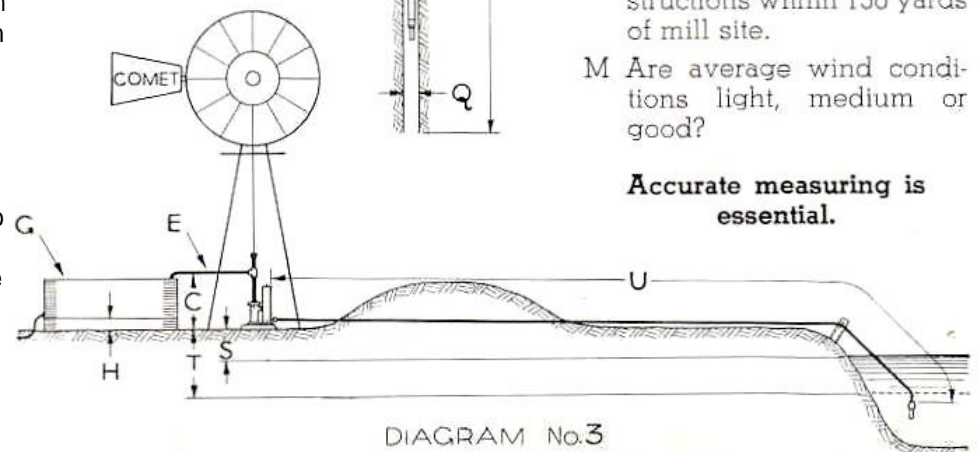
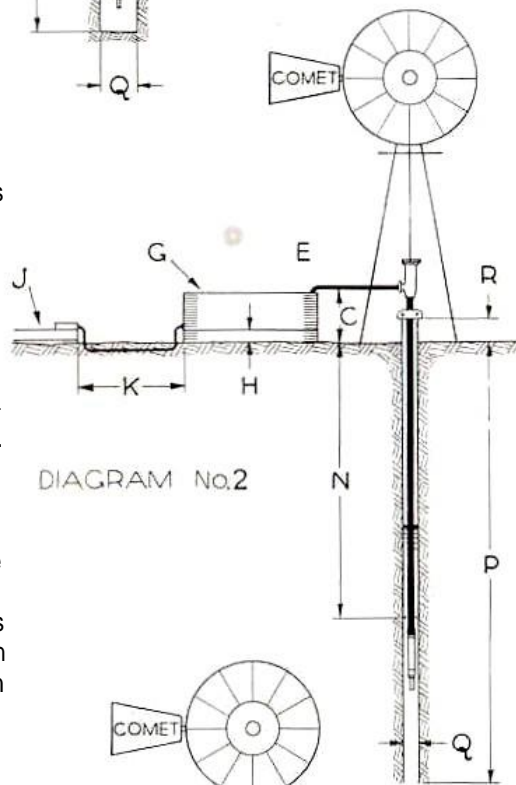
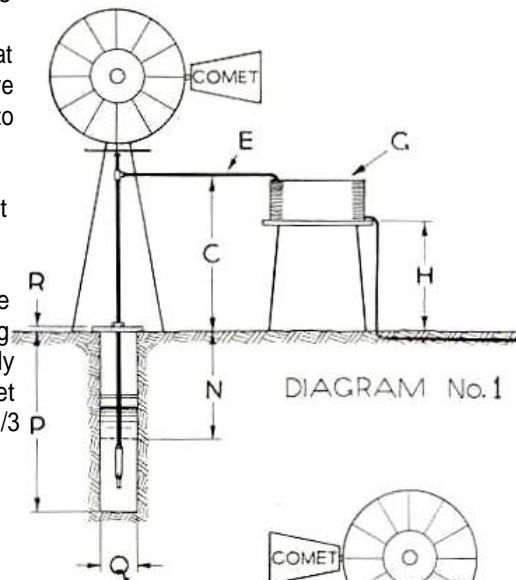

General Data

- A State the number of the diagram which is similar to your proposed layout. If your layout is different, please send a sketch showing dimensions below and details of any branch pipelines.
- B Number of gallons required per day.
- C Vertical height from ground level at mill site to point of discharge.
- D Vertical heights from ground level at mill to any rise or depression in delivery pipeline — see Diagram 5.
- E Length of discharge pipe or delivery pipeline.
- F Will pipeline be laid above or below ground level?
- G Capacity and type of storage tank.
- H Height of tankstand.
- J Length, size and type of troughing.
- K Length of pipe from tank to trough.
- L Distance and height of trees and other wind obstructions within 150 yards of mill site.
- M Are average wind conditions light, medium or good?

Accurate measuring is essential.

SELECTION GUIDE

Particulars Required For Design & Installation

COMET MILL PLANT DIAGRAMS

Pumping from Bores or Wells

- N Distance from ground level to lowest water level during pumping test.
- O Gallons pumped per hour during test.
- P Depth from ground level to bottom of bore or well.
- Q Outside diameter of bore casing or size of well.
- R Height of top of casing or well above ground.

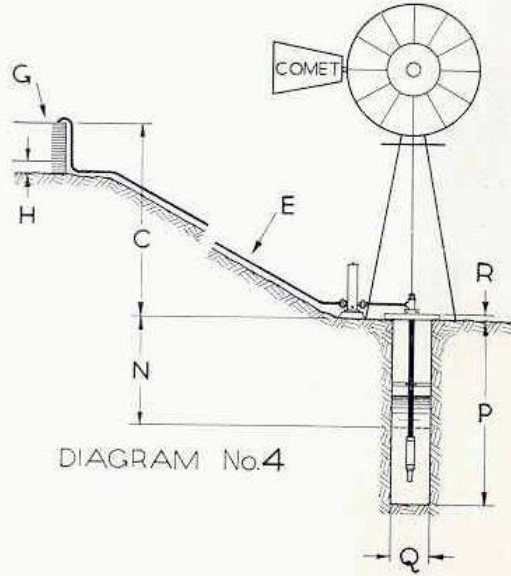
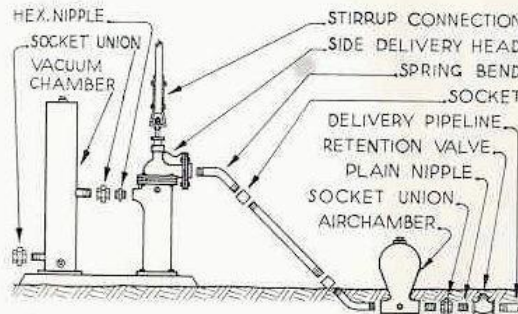

DIAGRAM No.4

Pumping from Creeks, Earth Tanks, Dams or Shallow Wells

- S Vertical height from normal water level to ground level at mill site.
- T Vertical height from lowest water level to ground level at mill site.
- U Length of suction pipe from footvalve to pump.
- V Vertical height above pump inlet of any unavoidable rise in suction pipeline.



TYPICAL SYPHON PUMP INSTALLATION SHOWING FITTINGS DISCONNECTED

Comet Mills on Other Towers

- 1 Size of pump in use.
- 2 Type of pump.
- 3 Size of delivery pipe.
- 4 Condition of pipes.
- 5 _____ ill and details of tower — see Particulars Folder.

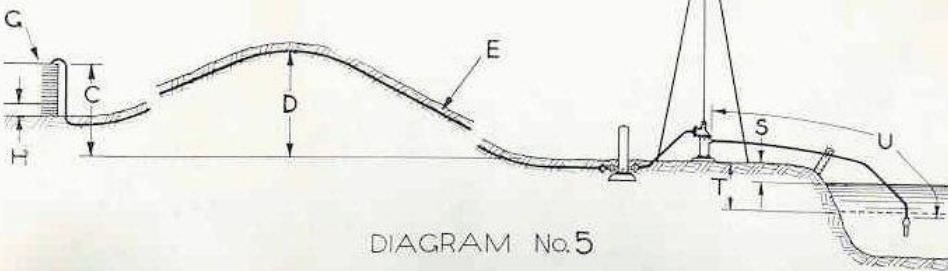
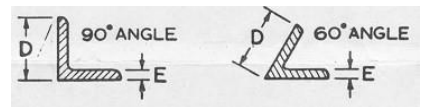

DIAGRAM No.5

COMET MILL HEADS ON OTHER TOWERS

The COMET Mill is often fitted to other makes of towers, even though it is not then covered by our guarantee. Please measure tower carefully and answer the relevant questions below. It is also important to supply all particulars of the pumping conditions, especially those in reference to sizes of existing pump, pipe etc. See Overleaf for more details.

- Make of existing Mill _____
- Size of existing Mill _____
- Height of existing tower _____
- Number of legs (3 or 4) _____
- Are legs 60° or 90° angle _____
- A Spread of legs at tower cap _____
- B Distance - cap to platform _____
- C Spread of tower at platform _____
- D Width of angle steel leg _____
- E Thickness of flange _____
- F Distance from cap to bend _____
- G Spread of tower at bend _____
- H Spread 4ft below bend _____



State type No. of your tower _____

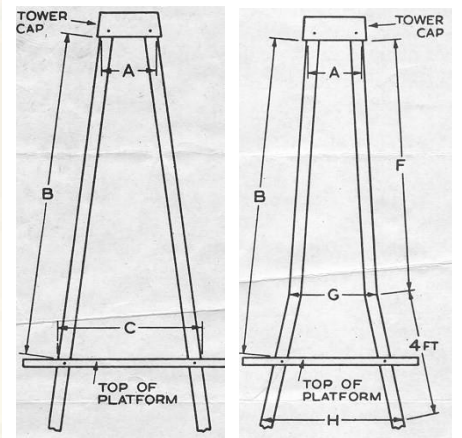

Type No. 1

Type No. 2

WINDMILL CODES

C Pattern Windmills

MAA	8ft	C Pattern
MBB	10ft	
MAB	8-10ft*	

MCC	12ft	C Pattern
MDD	14ft	
MCD	12-14ft*	

D Pattern Windmills

MQQ	16ft	D Pattern
MRR	18ft	
MQR	16-18ft*	

MSS	20ft	D Pattern
MTT	22ft	
MST	20-22ft*	

MUU	24ft	D Pattern
MVV	27ft	
MWW	30ft	
MUW	24-30ft*	
MVW	27-30ft*	

* Parts with these codes means that the parts are interchangeable with that size range. All other parts are specific for that size.

WINDMILL SYSTEMS

DIRECT ACTING WINDMILLS AND TOWERS

'C' PATTERN 8-14FT WHEEL DIAMETER

6-14FT WINDMILLS on a 4-POST TOWER

CODE	SIZE	TOWER SIZE			
		20ft	30ft	40ft	50ft
COM1001SS	8ft	\$ 7,000	\$ 7,500	\$ 7,900	
COM1002SS	10ft	\$ 7,500	\$ 7,900	\$ 8,400	
COM1003SS	12ft	\$ 9,000	\$ 9,500	\$ 10,500	\$ 10,900
COM1004SS	14ft		\$ 11,800	\$ 12,500	\$ 13,400

8-14FT WINDMILL HEADS

TO SUIT 4-POST TOWERS

COM1001	MA 2.4m (8ft) Windmill Head for 4-Post Tower	\$ 5,200
COM1002	MB 3.0m (10ft) Windmill Head for 4-Post Tower	\$ 5,700
COM1003	MC 3.6m (12ft) Windmill Head for 4-Post Tower	\$ 7,500
COM1004	MD 4.2m (14ft) Windmill Head for 4-Post Tower	\$ 8,900

All Windmills include Standard Safety Package (timber platform & ladder upgrade)

'D' PATTERN 16-22FT WHEEL DIAMETER

16-22FT WINDMILLS on a 4-POST TOWER

CODE	SIZE	TOWER SIZE			
		30ft	40ft	50ft	60ft
COM1037SS	16ft	\$ 22,400	\$ 24,400	\$ 25,400	
COM1038SS	18ft	\$ 22,500	\$ 24,600	\$ 25,600	
COM1039SS	20ft		\$ 28,500	\$ 30,400	
COM1040SS	22ft		\$ 28,600	\$ 30,500	

16-22FT WINDMILL HEADS

TO SUIT 4-POST TOWERS

COM1037	MQ 4.9m (16ft) Windmill Head for 4-Post Tower	\$ 17,800
COM1038	MR 5.5m (18ft) Windmill Head for 4-Post Tower	\$ 17,850
COM1039	MS 6.0 (20ft) Windmill Head for 4-Post Tower	\$ 22,900
COM1040	MT 6.7 (22ft) Windmill Head for 4-Post Tower	\$ 23,000

Sizes 24ft, 27ft and 30ft are also available—POA for more power and water

SAFETY UPGRADES FOR TOWERS (3-POST AND 4-POST)

To Suit Existing Towers (Galvanised steel platform with non-slip grate floor, perimeter toe plate, & ladder)

Safety First Platform and Ladder Upgrade	\$ 780
--	--------

Prices quoted are exclusive of GST and Freight



WINDMILL PUMPS FLUSH END CYLINDER PUMP

with pinned Plunger Rod for extra strength and stability

SIZES: 1¾" - 6"



FLUSH END PUMPS

CODE	SIZE	SUCTION	DISCHARGE	STROKE	ROD	PRICE
COM1077	1¾	25mm	40mm	12	½"	\$ 360
COM1078	2	32mm	40mm	12	½"	\$ 380
COM1079	2¼	32mm	40mm	12	5/8"	\$ 390
COM1080	2½	32mm	40mm	12	5/8"	\$ 450
COM1081	2¾	40mm	50mm	12	5/8"	\$ 480
COM1082	3	40mm	50mm	12	5/8"	\$ 490
COM1083	3¼	50mm	50mm	12	5/8"	\$ 510
COM1084	3½	50mm	50mm	12	¾"	\$ 680
COM1085	4	50mm	65mm	12	¾"	\$ 790
COM1086	4½	65mm	80mm	12	¾"	\$ 1,190
COM1087	5	65mm	80mm	12	¾"	\$ 1,290
COM1088	6	65mm	80mm	12	1"	\$ 1,490

The feature of Flush End Pumps are that the end caps are fitted flush with the outside of the barrel, enabling the maximum size of pump to be used in a given size of bore. Pumping from wells or shallow bores is the ideal application for the range of high quality, economical Comet Flush End Pumps. Comet Pumps are quality hand-made pumps for longer service. Pump construction of gun-metal and bronze and leather buckets ensures constant efficiency and satisfactory pumping in hard waters at total elevations of up to 200 feet.



HEAVY DUTY DRAW PLUNGER PUMPS

SIZES: 2" - 4¼"

STAINLESS STEEL SLEEVE VALVE DRAW PLUNGER PUMPS

CODE	SIZE inches	SUCTION	DISCHARGE	STROKE	ROD	PRICE
COM1108	2	32mm	65mm	24	5/8"	\$ 1,280
COM1109	2¼	32mm	65mm	24	¾"	\$ 1,390
COM1110	2½	40mm	80mm	24	¾"	\$ 1,480
COM1111	2¾	40mm	80mm	24	¾"	\$ 1,490
COM1112	3	50mm	100mm	24	¾"	\$ 1,520
COM1113	3¼	50mm	100mm	24	7/8"	\$ 1,880
COM1116	4¼	65mm	125mm	24	1"	\$ 2,490

Bronze Ball Valve and Mushroom Valve available by special order

Prices quoted are exclusive of GST and Freight.

Sleeve Valve
Pictured

WINDMILL PUMPS

SYPHON PUMP — vertical discharge

SIZES: 2" - 6"

VERTICAL DISCHARGE SYPHON PUMPS

CODE	SIZE	SUCTION	DISCHARGE	STROKE	ROD	PRICE
COM1117	2	32mm	50mm	12	5/8"	\$ 900
COM1118	2¼	32mm	50mm	12	5/8"	\$ 950
COM1119	2½	32mm	50mm	12	5/8"	\$ 985
COM1120	2¾	40mm	50mm	12	5/8"	\$ 1,035
COM1121	3	40mm	50mm	12	5/8"	\$ 1,140
COM1122	3¼	50mm	80mm	12	3/4"	\$ 1,200
COM1123	3½	50mm	80mm	12	3/4"	\$ 1,280
COM1124	4	50mm	80mm	12	3/4"	\$ 1,420
COM1125	4½	50mm	80mm	12	7/8"	\$ 1,680
COM1126	5	80mm	80mm	12	7/8"	\$ 1,980
COM1127	6	80mm	80mm	12	7/8"	\$ 2,270



SYPHON PUMP — side discharge

SIZES: 2" - 6"

SIDE DISCHARGE SYPHON PUMPS

CODE	SIZE	SUCTION	DISCHARGE	STROKE	ROD	Packing Tube	Ex GST
COM1128	2	32mm	40mm	12	5/8"	32mm	\$ 990
COM1129	2¼	32mm	40mm	12	5/8"	32mm	\$ 1,070
COM1130	2½	32mm	40mm	12	5/8"	32mm	\$ 1,090
COM1131	2¾	40mm	40mm	12	5/8"	32mm	\$ 1,220
COM1132	3	40mm	40mm	12	5/8"	32mm	\$ 1,240
COM1133	3¼	50mm	50mm	12	3/4"	40mm	\$ 1,390
COM1134	3½	50mm	50mm	12	3/4"	40mm	\$ 1,460
COM1135	4	50mm	50mm	12	3/4"	40mm	\$ 1,580
COM1136	4½	65mm	65mm	12	7/8"	40mm	\$ 1,810
COM1137	5	65mm	65mm	12	7/8"	45mm	\$ 2,490
COM1138	6	80mm	80mm	12	7/8"	45mm	\$ 2,800

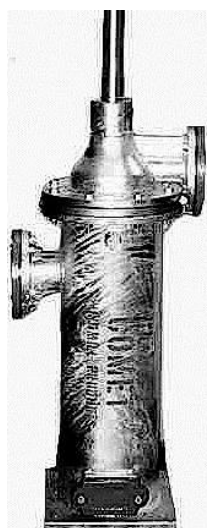

Prices quoted are exclusive of GST and Freight.

WINDMILL PUMPS

VERTICAL & SIDE



PLUNGER ASSEMBLY		STROKE		
CODE	SIZE	8"	10"	12"
COM111728PA	2	POA	POA	\$ 79.00
COM111829PA	2¼	POA	POA	\$ 89.00
COM111930PA	2½	POA	POA	\$ 96.00
COM112031PA	2¾	POA	POA	\$ 115.00
COM112132PA	3	POA	POA	\$ 125.00
COM112233PA	3¼	POA	POA	\$ 136.50
COM112334PA	3½	POA	POA	\$ 147.90
COM112435PA	4	POA	POA	\$ 192.80
COM112536PA	4½	POA	POA	\$ 269.90
COM112637PA	5	POA	POA	\$ 355.80
COM112738PA	6	POA	POA	\$ 389.50



INTERMEDIATE FLANGE, BARREL & BOTTOM CAP ASSEMBLY		STROKE		
		8"	10"	12"
COM111728FBA	2	POA	POA	\$ 299.00
COM111829FBA	2¼	POA	POA	\$ 333.00
COM111930FBA	2½	POA	POA	\$ 350.00
COM112031FBA	2¾	POA	POA	\$ 402.00
COM112132FBA	3	POA	POA	\$ 437.00
COM112233FBA	3¼	POA	POA	\$ 489.00
COM112334FBA	3½	POA	POA	\$ 520.00
COM112435FBA	4	POA	POA	\$ 589.00
COM112536FBA	4½	POA	POA	\$ 610.00
COM112637FBA	5	POA	POA	\$ 690.00
COM112738FBA	6	POA	POA	\$ 801.00

Prices quoted are exclusive of GST and Freight.

PUMP PARTS

PACKING TUBES



Packing Tube

Why COMET Windmills Are More Suitable For The Use of Packing Tubes

Comets' direct acting windmills have a distinct advantage over geared windmills by means of unique adjustable weights on the wheel arms to counter-balance the upthrust of the working parts and rods. This is not possible for geared mills as they require 4-7 turns for each pump stroke. This is the reason why Comet Windmills are suited to the packing tube principle and are known as 'Australia's Leading Mill'.

Sizes: 1¼" - 2"

PACKING TUBES						PRICE ex GST
CODE	SIZE inches	ROD inches	STROKE mm/in.	Minimum Pipe Size mm/in.		
COM1139	1¼	5/8	300 - 12	40 - 1½"	\$	196.00
COM1140	1¼	5/8	400 - 16	40 - 1½"	\$	196.00
COM1141	1½	¾	300 - 12	50 - 2"	\$	235.00
COM1142	1½	¾	400 - 16	50 - 2"	\$	240.00
COM1143	1¾	7/8	300 - 12	65 - 2½"	\$	255.00
COM1144	1¾	7/8	400 - 16	65 - 2½"	\$	260.00
COM1145	2	1	300 - 12	80 - 3"	\$	290.00
COM1146	2	1	400 - 16	80 - 3"	\$	320.00

TO SUIT SX SYPHON PUMPS

PACKING TUBE ADAPTORS				PRICE ex GST
CODE	Packing Tube ID	Column Pipe		
COM1147	1¼	1½	\$	180.00
COM1148	1½	2	\$	216.00
COM1149	1¾	2½	\$	226.00

Plunger: Quality made plunger assembly, **double pinned coupling** with **two inverted cup leathers** providing a reliable water seal.

Prices quoted are exclusive of GST and Freight.

Sockets are made in all sizes, plain and reducing

ROD SOCKETS		
CODE	SIZE	
COM1226	5/8	\$ 18.00
COM1227	¾	\$ 20.00
COM1228	7/8	\$ 22.00



1¼ - 1½ - 2" BSP

Prices quoted are exclusive of GST and Freight

PUMP PARTS



CODE	SIZE	PRICE
HAT WASHERS		
COM1160	5/8"	\$ 26.00
COM1161	3/4"	\$ 27.00
COM1162	7/8"	\$ 29.00

'Long-Life'



CODE	SIZE	PRICE
LEATHER PUMP BUCKET		
COM1165	32mm 1 1/4"	\$ 6.00
COM1166	40mm 1 1/2"	\$ 7.00
COM1167	45mm 1 3/4"	\$ 7.80
COM1168	50mm 2"	\$ 8.00
COM1169	57mm 2 1/4"	\$ 8.80
COM1170	65mm 2 1/2"	\$ 9.80
COM1171	70mm 2 3/4"	\$ 10.50
COM1172	80mm 3"	\$ 11.00
COM1173	82mm 3 1/4"	\$ 12.50
COM1174	90mm 3 1/2"	\$ 13.50
COM1175	95mm 3 3/4"	\$ 14.00
COM1176	100mm 4"	\$ 15.00
COM1177	106mm 4 1/4"	\$ 17.00
COM1178	115mm 4 1/2"	\$ 19.00
COM1179	125mm 5"	\$ 24.00
COM1180	130mm 5 1/4"	\$ 36.00
COM1181	150mm 6"	\$ 44.00



Large or small hole optional

CODE	SIZE	PRICE
RUBBER COMPOSITION PUMP BUCKET		
COM1185	32mm 1 1/4"	\$ 12.50
COM1186	40mm 1 1/2"	\$ 12.70
COM1187	45mm 1 3/4"	\$ 12.90
COM1188	50mm 2"	\$ 14.80
COM1189	57mm 2 1/4"	\$ 15.00
COM1190	65mm 2 1/2"	\$ 15.30
COM1191	70mm 2 3/4"	\$ 15.40
COM1192	80mm 3"	\$ 16.00
COM1193	82mm 3 1/4"	\$ 16.40
COM1194	90mm 3 1/2"	\$ 16.40
COM1195	95mm 3 3/4"	\$ 16.60
COM1196	100mm 4"	\$ 16.80
COM1197	106mm 4 1/4"	\$ 17.00
COM1198	115mm 4 1/2"	\$ 17.10
COM1199	125mm 5"	\$ 18.00
COM1200	130mm 5 1/4"	\$ 55.00
COM1200A	150mm 6"	\$ 56.40
COM1201	175mm 7"	\$ 68.70
COM1202	200mm 8"	\$ 77.70
COM1203	250mm 10"	\$ 86.00
COM1204	300mm 12"	\$ 99.50



Hot Water Artesian

COMPARE THE QUALITY

Prices quoted are exclusive of GST and Freight

TANK STANDS

TYPE 'S' TANKSTAND

(splayed legs)

The COMET Steel Tankstand is the ideal structure for supporting a water storage tank which needs to be elevated for a pressure supply. When properly erected on correct foundations COMET Tankstands withstand wind gales with safety. Designed so that accuracy and ease of assembly are assured, most holes have only 1/32 inch clearance for the bolts. Heavy steel footplates are welded to angle steel leg sections. The diagonal braces are flat steel bars, crossed in pairs so that they safely transfer the tensile loads imposed by winds from any direction. The bearers, joists and decking for COMET Tankstands are specially selected timber of the strongest and most durable species. Sizes are to individual requirements.

TYPE 'P' TANK

(parallel legs)

GALVANISED STEEL or HARDWOOD DECK



SIZES

5ft, 10ft, 20ft, 30ft heights
to suit any specified tank volume

Comet Type 'P' Tankstand

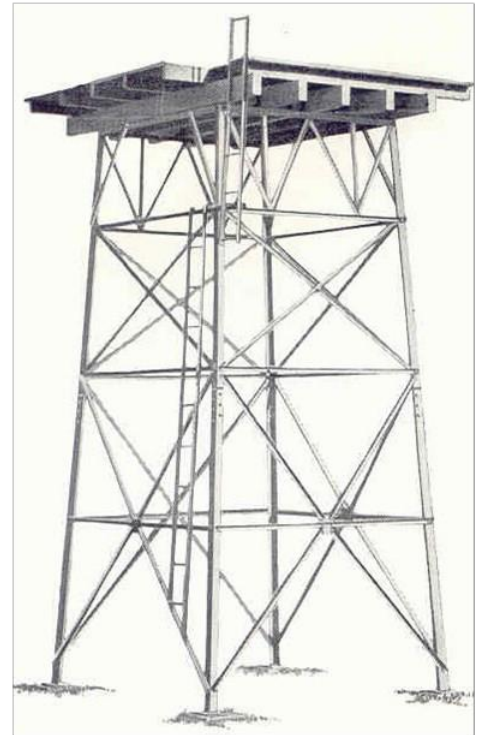

Comet Type 'S' Tankstand

FULLWAY FLOATVALVES

CODE	DESCRIPTION		PRICE
TYPE 'H' FULLWAY LOW PRESSURE FLOATVALVES			
	inches		
COM1420	1	Type 'H' Low Pressure Floatvalve	\$ 190.00
COM1421	1¼	Type 'H' Low Pressure Floatvalve	\$ 210.00
COM1422	1½	Type 'H' Low Pressure Floatvalve	\$ 260.00
COM1423	2	Type 'H' Low Pressure Floatvalve	\$ 290.00
COM1424	2½	Type 'H' Low Pressure Floatvalve	\$ 440.00
COM1425	3	Type 'H' Low Pressure Floatvalve	\$ 880.00
COM1426	4	Type 'H' Low Pressure Floatvalve	\$ 980.00

Built with a waterway as large as the pipe to allow maximum flow. Gunmetal construction is simple and the brass hinge pin protected so that sticking of the valve cannot occur in hard, gritty waters. Height of the float can be conveniently adjusted and set with the brass wedge. COMET Floatvalves are suitable for pressures to 20 feet head. 2½ - 4" suitable for Concrete Troughs.

TYPE 'E' HIGH PRESSURE FLOATVALVE

	inches	Suitable for use in both Steel and Concrete Troughing	
COM1427	1¼	Type 'E' High Pressure Floatvalve	\$ 28.00
COM1428	1½	Type 'E' High Pressure Floatvalve	\$ 320.00
COM1429	2	Type 'E' High Pressure Floatvalve	\$ 380.00

Water at pressures higher than 20 feet can be regulated with the COMET E Type Equilibrium Floatvalve. This valve operates effectively at pressures up to 150 feet without danger of shimmying, and valve opening is equal to the full bore of the pipe. Sizes 1¼", 1½" and 2" pipe.

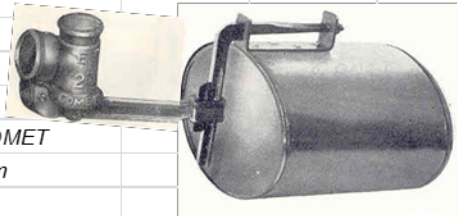

E' Type pictured with a COMET Brass Float and Fixed Arm

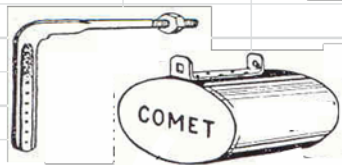

1½" to 4" Fixed Float and Arm

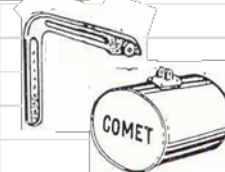

½" to 4" Swivelling Float and Arm



A floatvalve regulates the water supplied to stock from the storage tanks. For this important function it must permit at times an inrush of water to the trough for mobs of thirsty sheep or cattle, and yet remain closed without leakage for long periods.

'H' Type pictured with a COMET Brass Float

Prices quoted are exclusive of GST and Freight

WINDMILL PARTS

WHEEL ASSEMBLY

C PATTERN

WHEEL ASSEMBLY 8, 10, 12, 14ft

CODE	QUANTITY	PRICE
COM1001W	8ft Wheel Assembly Less Hub, Bolts & Balance Weights	\$ 1,490
COM1001WH	8ft Wheel Assembly Complete, with Hub, Bolts & Balance Weights	\$ 1,590
COM1002W	10ft Wheel Assembly Less Hub, Bolts & Balance Weights	\$ 1,790
COM1002WH	10ft Wheel Assembly Complete, with Hub, Bolts & Balance Weights	\$ 1,990
COM1003W	12ft Wheel Assembly Less Hub, Bolts & Balance Weights	\$ 2,000
COM1003WH	12ft Wheel Assembly Complete, with Hub, Bolts & Balance Weights	\$ 2,290
COM1004W	14ft Wheel Assembly Less Hub, Bolts & Balance Weights	\$ 2,450
COM1004WH	14ft Wheel Assembly Complete, with Hub, Bolts & Balance Weights	\$ 2,650



D PATTERN

WHEEL ASSEMBLY 16, 18, 20, 22ft

CODE	QUANTITY	PRICE
COM1037W	16ft Wheel Assembly Less Hub, Bolts & Balance Weights	\$ 5,390
COM1037WH	16ft Wheel Assembly Complete, with Hub, Bolts & Balance Weights	\$ 6,900
COM1038W	18ft Wheel Assembly Less Hub, Bolts & Balance Weights	\$ 5,400
COM1038WH	18ft Wheel Assembly Complete, with Hub, Bolts & Balance Weights	\$ 7,200
COM1039W	20ft Wheel Assembly Less Hub, Bolts & Balance Weights	\$ 7,200
COM1039WH	20ft Wheel Assembly Complete, with Hub, Bolts & Balance Weights	\$ 8,700
COM1040W	22ft Wheel Assembly Less Hub, Bolts & Balance Weights	\$ 8,400
COM1040WH	22ft Wheel Assembly Complete, with Hub, Bolts & Balance Weights	\$ 9,900

Prices quoted are exclusive of GST and Freight

COMET®

WINDMILL PRODUCTS

WINDMILL TYPE	Mill Size Wheel Diam.		No. Sails	No. Arms	No. Inner Rims	No. Middle Rims	No. Outer Rims	No. Brackets	Bracket No.
	Foot	metre							
'C' PATTERN MILL	6	1.83	12	4	2	-	4	12	0 0
	8	2.44	12	4	2	-	4	12	1 2
	10	3.05	18	6	3	-	6	18	1 2
	12	3.66	18	6	3	-	6	18	3 4
	14	4.27	24	8	4	-	8	24	3 4
'D' PATTERN MILL	16	4.88	24	8	8	-	8	24	3 4
	18	5.49	24	8	8	-	8	24	3 5
	20	6.10	24	8	8	8	8	24	3 4 5
	22	6.71	30	10	10	10	10	30	3 4 5
	24	7.32	30	10	10	10	10	30	6 7 8
	27	8.23	36	12	10	10	10	36	6 7 8
	30	9.14	42	14	14	14	14	42	6 7 8

Prices quoted are exclusive of GST and Freight

WINDMILL PARTS

OVERHAUL KITS — C PATTERN

The Comet 'C' Pattern Mills have earned a wide reputation for great pumping capacity and longer trouble-free service. Extreme sensitivity to changes in wind direction, together with effective governing for safety in storms, means simply that the Comet will outperform any other mill of similar size. Made in five (4) sizes the 8ft to 14ft Comet Mills are direct acting for better efficiency and great strength. The fewer working parts mean less friction loss than geared mills. The Comet makes more use of the small power available in the prevalent light winds.

The exceptionally strong main casting with integral mast pipe is accurately machined to close tolerances. The unique Comet Hardwood Bearing Bushes make by far the best bearings for the slow speed, heavy duty work of a windmill and a great many of them have been in service for over 30years.

The cast iron crank with steel pin is shrunk and keyed to the bright steel driving shaft and cannot work loose. Thrust is taken between machined faces of the main casting and wheel hub.

MAJOR Overhaul Kit 8—14ft — Driveshaft, Connecting Rod, Crosshead (incl. pin/dowel), Swivel, choice of wood or nylon bearings.

CODE		PRICE
MAA1000	Major Overhaul Packages 8ft	\$ 1,250
MBB1000	Major Overhaul Packages 10ft	\$ 1,260
MCC1000	Major Overhaul Packages 12ft	\$ 1,700
MDD1000	Major Overhaul Packages 14ft	\$ 1,710

MINOR Overhaul Kit 8 - 14ft — Connecting Rod, Crosshead (incl. pin/dowel), Swivel, choice of wood or nylon bearings.

CODE		PRICE
MAB1000	Minor Overhaul Packages 8-10ft	\$ 750
MCD1000	Minor Overhaul Packages 12—14ft	\$ 990

REPAIR Kit 8-14ft

CODE		PRICE
MAB1034	8-10ft Upper/Lower Turntables complete	\$ 599
MCD1034	12-14ft Upper/Lower Turntables complete	\$ 699
MAB1035	8-10ft Inner/Outer Pullout Collars complete	\$ 410
MCD1035	12-14ft Inner/Outer Pullout Collars complete	\$ 490
MAB1036	8-10ft Roller Guide complete	\$ 360
MCD1036	12-14ft Roller Guide complete	\$ 425

Prices quoted are exclusive of GST and Freight

PARTS ILLUSTRATION
8, 10, 12, 14ft C PATTERN WINDMILLS

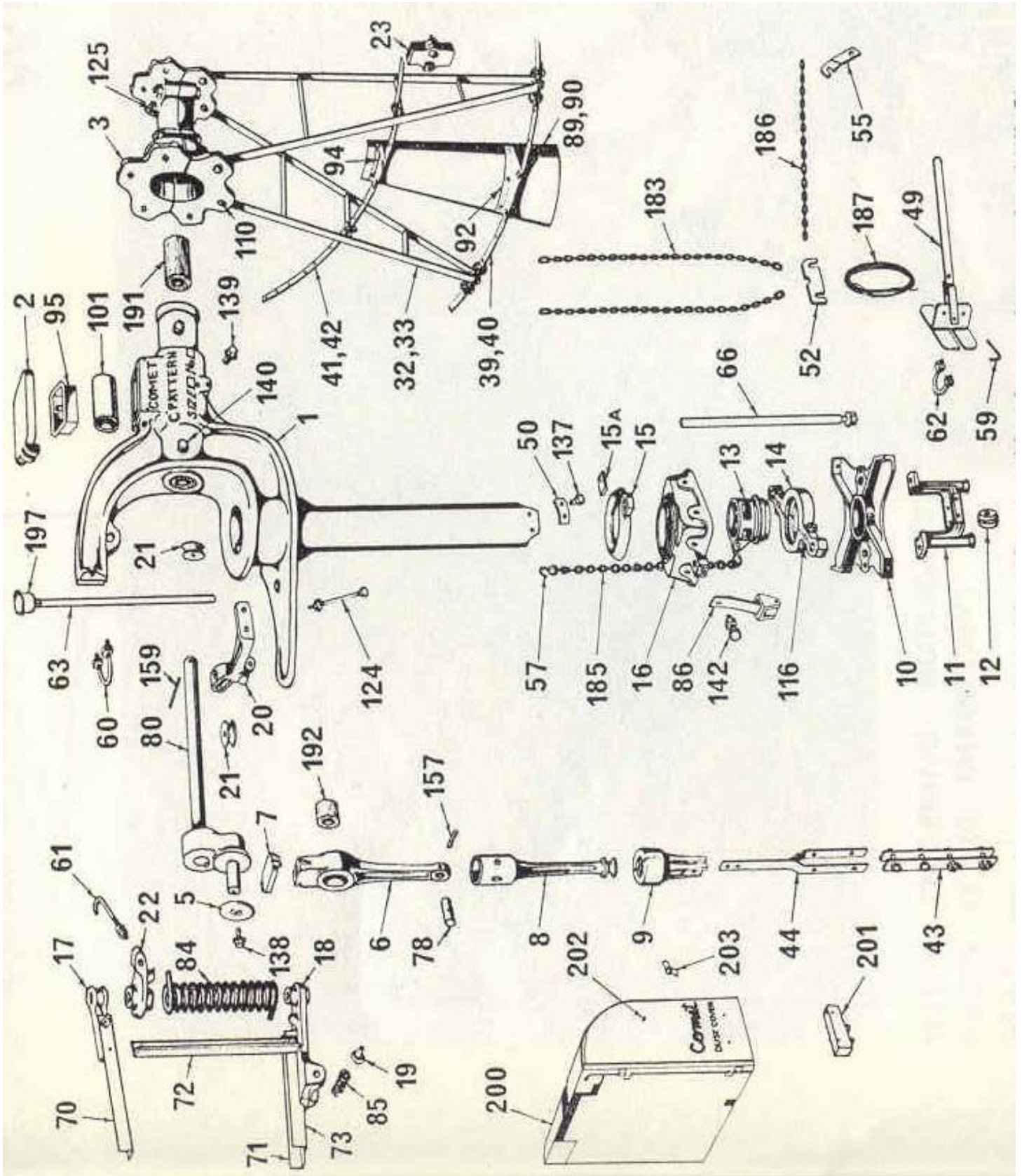

Prices quoted are exclusive of GST and Freight

LIST OF PARTS 8, 10, 12, 14ft C PATTERN MILLS

- | | |
|--|---|
| 1 Main Casting Complete Incl. 2, 50, 95, 137, 139, 140, 191 | 90 Sail – One only |
| 2 Oil Lid for Main Casting | 91 Outer Sail Brackets – Complete Set |
| 3 Hub Complete Incl. 125 | 92 Outer Sail Bracket – One only |
| 5 Crank Pin Washer | 93 Inner Sail Brackets – Complete Set |
| 6 Connecting Rod Complete Incl. 7, 78, 157, 192 | 94 Inner Sail Bracket – One only |
| 7 Oil Lid for Connecting Rod | 95 Galvanised Oil Box for Main Casting |
| 8 Crosshead Incl. 120 | 101 Ring Oiler Tube |
| 9 Swivel Incl. 120 | 105 Galv. Bolts – Sail Brackets to Rims |
| 10 Bottom Guide Complete Incl. 10A | 106 Galv. Bolts – Sail Brackets to Sails |
| 10A Grease Cup for Bottom Guide | 107 Bolts – Lap of Outer Rims |
| 11 Roller Guide Complete Incl. 12, 128 | 108 Bolts – Inner Rims to Arms at Lap |
| 12 Rollers for Roller Guide | 109 Bolts – Outer Rims to Arms |
| 13 Inner Pullout Collar | 110 Bolts – Arms to Hub |
| 14 Outer Pullout Collar Complete Incl. 116 | 111 Bolts – Inner Rims to Arms |
| 15 Top of Turntable Complete Incl. 15A | 112 Bolts – Vane Sheet to Vane Angles |
| 15A Oil Lid for Turntable | 113 Bolt – Upright Vane Angle |
| 16 Tower Cap | 114 Bolt – Outer End of Vane Angles |
| 17 Top Vane Hinge Casting | 115 Bolts – Bottom Guide to Tower |
| 18 Bottom Vane Hinge Casting Complete Incl. 19, 85 | 116 Bolts – Outer Pullout Collar |
| 19 Buffer Studs | 117 Bolts – Tower Cap to Tower |
| 20 Pullout Bracket Complete Incl. 21, 122 | 119 Bolts – Pullout Bracket to Main Casting |
| 21 Chain Rollers | 120 Bolts – Swivel to Guide Bar |
| 22 Tension Casting | 121 Bolts – Top Vane Hinge Casting to Angle |
| 23 Balance Weights Complete Incl. 126 | 122 Bolt – Chain Roller on Pullout Bracket |
| 32 Wheel Arms – Complete Set | 124 Stay Bolt for Pullout Bracket |
| 33 Wheel Arm – One only | 125 Clamp Bolts for Hub |
| 39 Outer Rims – Complete Set | 126 Bolts – Balance Weights |
| 40 Outer Rim – One only | 127 Bolts – Connecting Straps to Mill Rod |
| 41 Inner Rims – Complete Set | 128 Bolts – Rollers on Rollerguide |
| 42 Inner Rim – One only | 129 Bolt – Chain Roller on Main Casting |
| 43 Fishplates for joining Mill Rods | 137 Set Screws for 50 |
| 44 Connecting Straps for Guide Bar | 138 Set Screws for 5 |
| 49 Pullout Lever Complete Incl. 59 | 139 Set Screw with Leather Washer – for Oil Well |
| 50 Stop Bracket on Mast Pipe | Draining Hole and Oil Level Hole |
| 52 Equalizing Bar | 140 Set Screw for Drive Shaft Bearing Bushes |
| 55 Chain Plate | 142 Set Screw for 86 |
| 57 'S' Hooks for Pullout Chain | 157 Through Pin for Crosshead Pin |
| 59 Stop Pin for Pullout Lever | 159 Through Pin for Drive Shaft |
| 60 'U' Clip for Vane Hinge Rod with Nuts and Washers | 182 Steel Balls for Turntable |
| 61 Tension Bolt with Nuts | 183 Double Pullout Chain Complete Incl. 52 |
| 62 'U' Clip for Pullout Lever with Nuts and Washers | 185 Pullout Chain for Vane Complete Incl. 57 |
| 63 Vane Hinge Rod Incl. 197 | 186 Check Chain |
| 66 Pullout Guide Rod with Nut and Lock Washer | 187 Galv. Pullout Wire |
| 69 Vane Frame – Complete Incl. 17, 18, 70, 71, 72, 73 | 190 Mill Rods |
| 70 Top Vane Angle | 191 Drive Shaft Bearing Bushes (set) |
| 71 Stiffening Vane Angle | 192 Connecting Rod Bearing Bushes |
| 72 Upright Vane Angle | 196 Syphon Wicks for Oil Wells |
| 73 Bottom Vane Angle | 197 Oil Cup for 63 |
| 78 Crosshead Pin Complete Incl. 157 | 200 Dust Cover Complete Incl. 201, 202, 203. |
| 80 Driving Shaft Complete with Crank, Crank Pin, 5, 138, 159 | 201 Oil Box in Dust Cover |
| 84 Governor Spring | 202 Fastening Bolt for Dust Cover |
| 85 Buffer Spring | 203 Wing Nut for 202 |
| 86 Latch Spring Complete with Latch | 189 Pullout Winch Complete (Not Available). This was |
| 88 Vane Sheet Complete with Galv. Straps | between 1938-1942. If a replacement or any parts are |
| 89 Sails – Complete Set | required Part 49 Pullout Lever Complete will be supplied. |
| Note:- The following parts were used prior to 1940 and are not inter-changeable with Double Chain Pullout Parts of similar description used since 1940. | |
| 10 Pipe Pullout Bottom Guide Complete Incl. 10A. | 14 Pipe Pullout Outer Collar Complete Incl. 116 |
| 11 Pipe Pullout Roller Guide Complete Incl. 12, 128. | 100 Pullout Pipe with Split Pin |

WINDMILL PARTS

OVERHAUL KITS — D PATTERN

MAJOR Overhaul Kit 16-30ft — Driveshaft, Connecting Rod, Crosshead (incl. pin/dowel), Swivel, choice of wood or nylon bearings.

CODE		PRICE
MQQ1000	Major Overhaul Packages 16ft	\$ 2,400
MRR1000	Major Overhaul Packages 18ft	\$ 2,600
MSS1000	Major Overhaul Packages 20ft	\$ 2,900
MTT1000	Major Overhaul Packages 22ft	\$ 3,100
MUU1000	Major Overhaul Packages 24ft	\$ 3,600
MVV1000	Major Overhaul Packages 27ft	\$ 3,800
MWW1000	Major Overhaul Packages 30ft	\$ 4,000

MINOR Overhaul Kit 16 - 30ft — Connecting Rod, Crosshead (incl. pin/dowel), Swivel, choice of wood or nylon bearings.

CODE		PRICE
MQR1000	Minor Overhaul Packages 16-18ft	\$ 1,790
MST1000	Minor Overhaul Packages 20—22ft	\$ 2,190
MUW1000	Minor Overhaul Packages 24, 27, 30ft	\$ 2,600

REPAIR Kit 16-30ft

CODE		PRICE
MQR1000MR	Mastpipe c/w stop brackets 16—18ft	\$ 2,600
MST1000MR	Mastpipe c/w stop brackets 20—22ft	\$ 3,300
MUW1000MR	Mastpipe c/w stop brackets 24, 24, 27ft	\$ 3,800
MQR1000TR	Upper/lower Turntables complete 16—18ft	\$ 1,490
MST1000TR	Upper/lower Turntables complete 20—22ft	\$ 1,590
MUW1000TR	Upper/lower Turntables complete 24, 27, 30ft	\$ 1,790
MQR1000CR	Inner/Outer Pullout Collars complete 16—18ft	\$ 980
MST1000CR	Inner/Outer Pullout Collars complete 20—22ft	\$ 1,150
MUW1000CR	Inner/Outer Pullout Collars complete 24, 27, 30ft	\$ 1,480
MQR1000WR	Thrust Washer complete 16—18ft	\$ 520
MST1000WR	Thrust Washer complete 20—22ft	\$ 610
MUW1000WR	Thrust Washer complete 24, 27, 30ft	\$ 680
MQR1000RR	Roller complete with spindle 16—18ft	\$ 390
MST1000RR	Roller complete with spindle 20—22ft	\$ 480
MUW1000RR	Roller complete with spindle 24, 27, 30ft	\$ 780

Pag

PARTS ILLUSTRATION
16, 18, 20, 22ft D PATTERN WINDMILLS

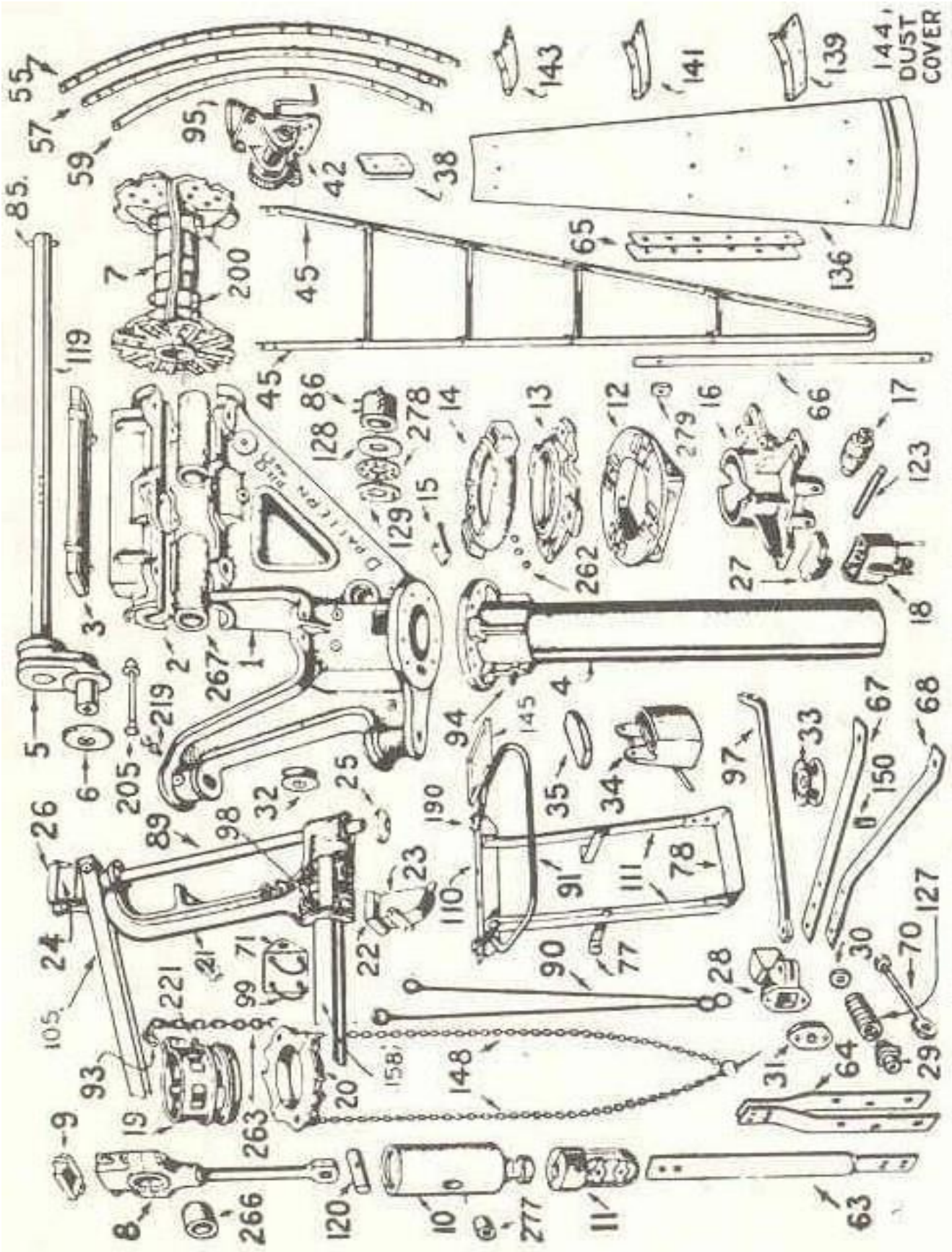

ONLY USE GENUINE COMET QUALITY PARTS

LIST OF PARTS 16, 18, 20, 22ft D PATTERN MILLS

CASTINGS

- 1 Main Casting
- 2 Bearing Cover on Main Casting
- 3 Oilbox Lid for Bearing Cover
- 4 Mast Pipe
- One-piece Crank and Pin (Fixed on shaft)
- 6 Crank Pin Washer
- 7 Hub Casting Clamp-on Type
- 8 Connecting Rod
- 9 Oilbox Lid for Conn. Rod (Until 1960)
- 10 Crosshead
- 11 Swivel
- 12 Tower Cap
- 13 Bottom Part of Ball-Bearing Turntable
- 14 Top Part of Ball-Bearing Turntable
- 15 Oilbox Lids for Turntable
- 16 Bottom Guide for Mast Pipe
- 17 Rollers for Bottom Guide
- 18 Oilboxes For Rollers
- 19 Inner Collar for Pullout
- 20 Outer Collar for Pullout
- 21 Vane Hinge Casting
- 22 Oilbox Lid for 23
- 23 Bottom Oilbox for Vane
- 24 Top Oilbox for Vane
- 25 Self-aligning Washer for Vane
- 26 Oilbox Lid for 24
- 27 Oilbox Lid for 18
- 28 Spring Buffer Casting
- 29 Buffer Studs
- 30 Washer on Buffer Bar
- 31 Buffer Box Flange
- 32 Chain Roller on Main Casting
- 33 Chain Roller on Pull-out Bars
- 34 Oilboxes for Crosshead (Until 1960)
- 35 Lids for Crosshead Oilboxes
- 38 Balance Weights
- 42 Pullout Winch complete

FLAT BAR PARTS

- 45 Wheel Arms – Complete Set
- 46 Wheel Arm – one only
- Rims – complete set
- 55 Outer Rims – complete
- 56 Outer Rim – one only
- 57 Middle Rims – complete
- 58 Middle Rim – one only
- 59 Inner Rims – complete
- 60 Inner Rim – one only
- 63 Steel Draw Bar
- 64 Connecting Straps on Steel Draw Bar

- 65 Fish Plates joining Mill Rods
- 66 Guide Bar
- 67 Top Bar for Pull-out Bracket
- 68 Bottom Bar for Pull-out Bracket 5
- 70 Eye Bolt for Spring Buffer
- 71 Buffer and Chain Plate
- 73 Check Rod Plate on Vane
- 74 Vane Straps – inner
- 74A Vane Straps – inner middle
- 75 Vane Straps – middle
- 76 Vane straps – outer
- 77 Stay for Inspection Frame to Main Casting
- 78 Foot Plate
- 105 Vane Stay Straps

ROUND BAR PARTS

- 85 Plain Pin through Shaft on Hub
- 86 Thrust Collar
- 89 Vane Hinge Rod
- 90 Check Rod for Vane
- 91 Guard Rail for Inspection Frame
- 93 Connecting Link for Pull-out Collars
- 94 Check Stud on Mast Pipe (Until 1959)
- 95 “U” Clips for Winch
- 97 Pull-out Bracket Stay
- 98 “U” Bolts for Vane Hinge Casting
- 99 “U” Bolts for 71

ANGLE STEEL PARTS

- 110 Support Angle for Inspection Frame
- 111 Side Angles for Footplate
- 112 Inspection Frame Complete

POLISHED STEEL PARTS

- 119 Driving Shaft (fitted with Crank & Pin)
- 120 Crosshead Pin
- 121 Cotter Pin for Crosshead Pin
- 123 Axles for Rollers on Bottom Guide

SPRING STEEL PARTS

- 127 Buffer Spring
- 128 Front Thrust Washer
- 129 Back Thrust Washer
- 130 Thrust Washer Complete (Front Back & 54 Balls with Cage)

GALVANISED IRON PARTS

- 134 Vane Sheet Complete
- 135 Sails – complete set
- 136 Sail – one only
- 137 Sail Brackets – complete set
- 138 Outer Sail Brackets – complete set
- 139 Outer Sail Bracket – one only
- 140 Middle Sail Brackets – complete set

PARTS ILLUSTRATION
24, 27, 30ft D PATTERN WINDMILLS

HOW TO ORDER GENUINE COMET SPARE PARTS

When ordering GENUINE spare parts it is important to state:

1. Part Number 2. Name of Part 3. Size of Mill 4. Registered Serial Number of Mill*

* When any improvements are made in Comet Mills a proper record is kept in our Office. The alterations are recorded against the size and serial numbers of the mills that have the alterations, and also the period over which the alterations hold good. Delay is avoided if the serial number of the mill is supplied when ordering genuine spare parts which also ensures the genuine parts are correct. The size and registered serial number of COMET Mills are found on the side of the main casting, the vane sheet and driving shaft (crank).

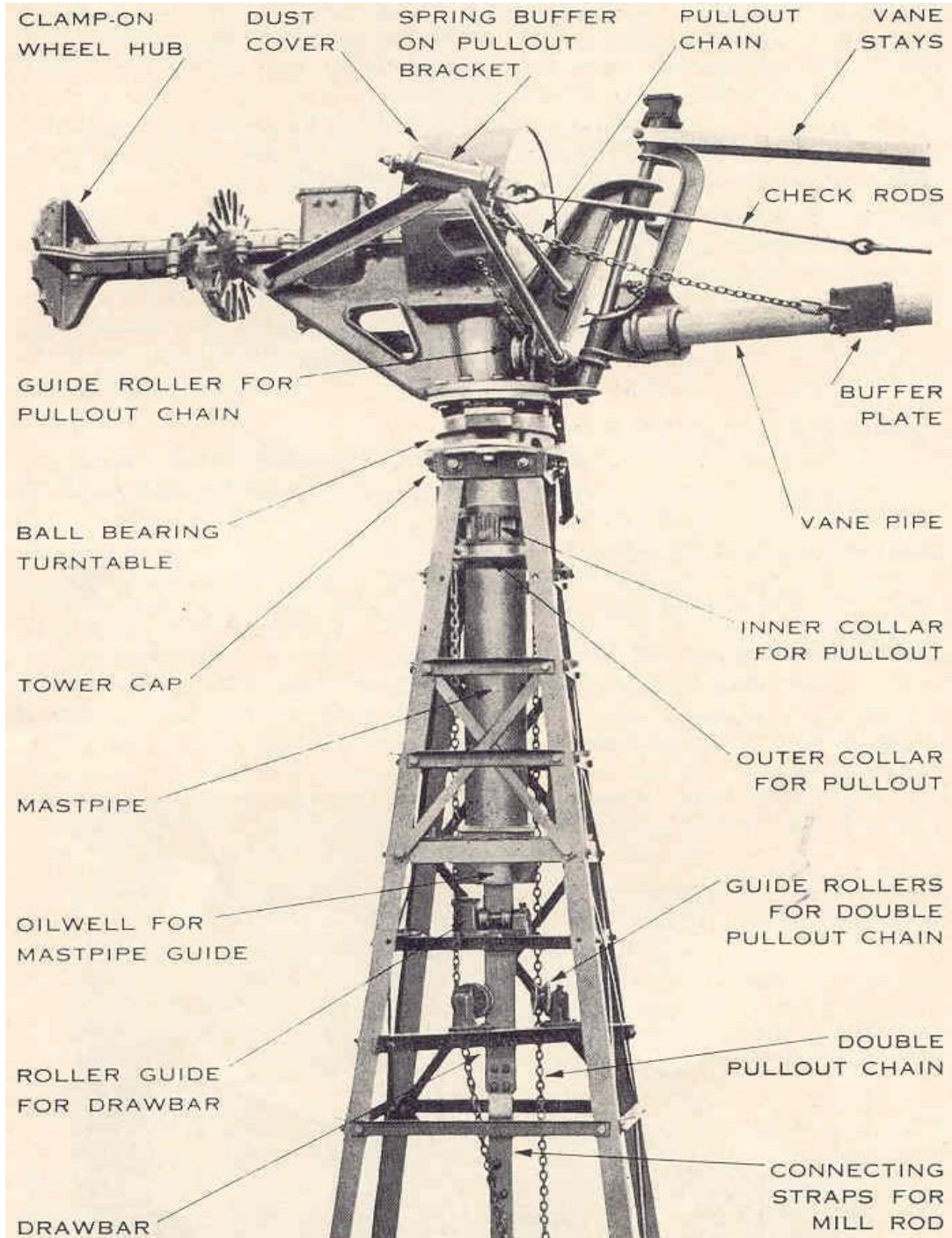

D' Pattern Mill, less wheel and vane. Note the totally enclosed design, simplicity of construction and great strength of all components.

ONLY USE GENUINE COMET QUALITY PARTS

PARTS ILLUSTRATION
24, 27, 30ft D PATTERN WINDMILLS

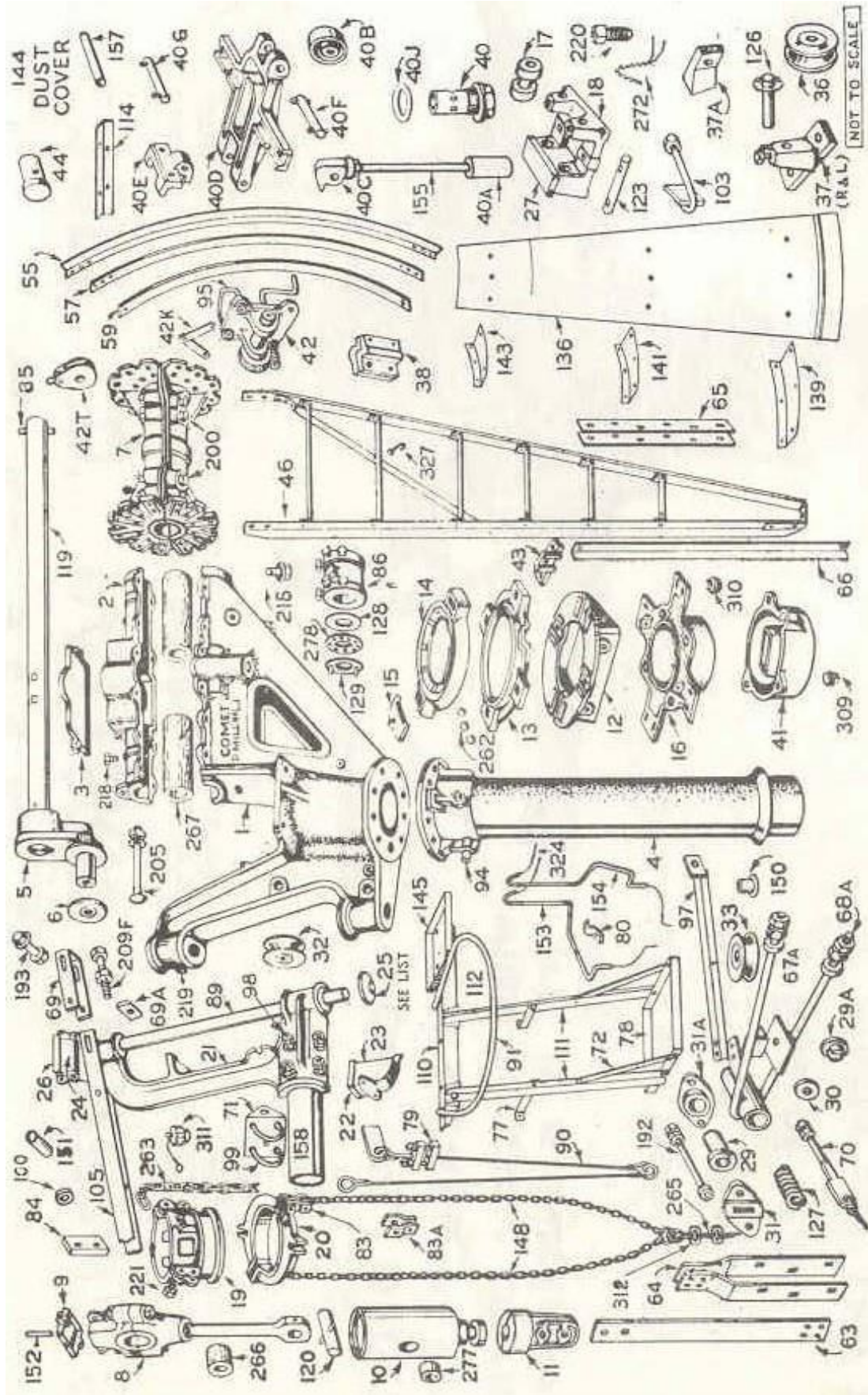

LIST OF PARTS 24, 27, 30ft D PATTERN MILLS

Product Codes:

MUU - 24' ONLY; MVV - 27'; MWW - 30' ONLY; MVW - 27', 30'; MUW - 24', 27' & 30'

79 Shackle on Check Rod to Vane 27/30' only – until 1953

80 Clip for Crosshead Oil Tubes

83 Connecting Links – Chain to Inner Collar

83A Connecting Links – Chain to Outer Collar

84 Inner Collar Guide Key

105 Vane Stays

ROUND BAR PARTS

85 Plain Pin through Shaft on Hub

86 Thrust Collar

89 Vane Hinge Rod

90 Check Rod for Vane

91 Guard Rail for Inspection Frame, Welded to Support Angle

93 Long Link – Pullout Collar to Conn. Link

94 Check Stud on Mast Pipe (Until 1959)

95 'U' Clips for Winch

97 Pull-out Bracket Stay

98 'U' Bolts for Vane Hinge Casting

99 'U' Bolts for 71

100 Spacer between Connecting Links

103 Hook Bolts for 107A

ANGLE STEEL PARTS

107 Support Rails for Roller Guide

107A Support Rails for Guide Roller

110 Support Angle for Inspection Frame

111 Side Angles for Footplate

112 Inspection Frame Complete

114 Stiffening Angle for Dust Cover

POLISHED STEEL PARTS

119 Driving Shaft (fitted with Crank & Pin)

120 Crosshead Pin

121 Cotter Pin for Crosshead Pin

123 Spindles for Roller Guide

126 Axles for Guide Rollers

SPRING STEEL PARTS

127 Buffer Spring

128 Front Thrust Washer

129 Back Thrust Washer

130 Thrust Washer Complete (Front Back & Balls with Cage)

GALVANISED IRON PARTS

134 Vane Sheet Complete

135 Sails – complete set

136 Sail – one only

137 Sail Brackets – complete set

138 Outer Sail Brackets – complete set

139 Outer Sail Bracket – one only

140 Middle Sail Brackets – complete set

141 Middle Sail Bracket – one only

142 Inner Sail Brackets – complete set

143 Inner Sail Bracket – one only

144 Dust Cover (With Oilbox from 1960)

145 Tool Tray

146 Chain Guard below 33

TUBE PARTS

150 Ferrule for Chain Roller

151 Spacer on Vane Stays

152 Oil Tube for Conn. Rod

153 Oil Tube for Crosshead – R.H

154 Oil Tube for Crosshead – L.H

155 Oil Pump Tube for Oil Plunger

157 Distance Pipe for Dust Cover

158 Vane Pipe

BOLTS FOR WHEEL

160 Arms to Hub Casting

161 Inner Rims to Arms

162 Middle Rims to Arms

163 Laps of Middle Rims

164 Outer Rims to Arms

165 Laps of Outer Rims

166 Sail Brackets to Rims

167 Sail to Sail Brackets

BOLTS FOR MILL HEAD & VANE

170 Roller Guide Support Rails to Tower

171 Footplate Stays to Main Casting

172 Footplate & Stays to Frame

172A Footplate Braces to Footplate

172B Footplate Braces to Side Angles

173 Pullout Collar to Connecting Links

174 Footplate Frame to Support

175 Guide Bar Bracket to Tower Rail

176 Guide Bars to Bottom Guide

177 Guide Bars to Guide Bar Bracket (Until 1960)

178 Inner Pullout Collar

179 Inner Pullout Collar Dowel Bolt

179A Inner Pullout Collar Dowel Bolt

180 Vane Straps and Stays to Pipe

181 Bottom Guide to Tower

182 Pullout Collar (Outer)

183 Connecting Straps to Draw Bar

184 Vane Sheet to Straps

185 Oil Well to Bottom Guide

186 Guide Roller Bracket to Support Angle

187 Chain Roller on Pull-out

188 Clamp Bolts – Vane Straps and Sheet to Pipe

189 Top Bracket Bar to Buffer Casting (27/30')

189A Bottom Bracket Bar to Buffer Casting (27/30')

191 Footplate support to Main Casting

192 Spring Buffer Body to Flanges (24')

192A Spring Buffer Body to Flange (27/30')

193 Vane Stays to Hinge Casting

194 Bottom Bar to Buffer Casting (27/30')

194A Stay to Buffer

195 Bottom Bar to Main Casting (27/30')

195A Stay to Main Casting

196 Top Bar to Buffer Casting (27/30')

196A Top Bar to Main Casting (27/30')

LIST OF PARTS 24, 27, 30ft D PATTERN MILLS

Product Codes:

MUU - 24' ONLY; MVV - 27'; MWW - 30' ONLY; MVW - 27', 30'; MUW - 24', 27' & 30'

197 Main Swivel	231 Oilbox Cover for Bearing Cover
198 Main Bearing Cap – Long	232 Oilbox Cover for Bottom Vane Hinge
198A Main Bearing Cap – Short	233 Oilpump Cam Roller
199 Top Distance Casting (39) to Angle (27/30')	234 Eye Bolt on Buffer
199A Bottom Distance Casting (39A) to Angle (27/30')	235 Guide Roller Axles
200 Hub Casting	236 Roller Guide Spindles
201 Connecting Rod	236A Conn. Rod Oilbox Lid (until 1960)
202 Bolts for Tool Tray	237 Turntable Oilbox Lid
204 Connecting Straps to Mill Rod	PLAIN WASHERS
205 Crank Pin Washer to Crank	235A Washers for 235
206 Tower Cap to Legs	239 Crank Pin Bolt Washer
207 Turntable to Tower Cap	242 Distance Washer for Eye Bolt
208 Chain Roller on Main Casting	331 Washer under Chain Roller
209 Fish Plates	LOCK WASHERS FOR WHEEL BOLTS
209F Adjusting Screw for 69 (24' until 1952) (27/30' until 1953)	For Galvd. Bolts through Sails and Brackets.
280 Mast Pipe to Main Casting	For Bolts through Rims and Arms
280A Mast Pipe to Main Casting – Fitted	For Bolts through Arms and Hub Casting
287 Hinge Casting to Top Oilbox	(Most of the other bolts in mill also have lock washers)
288 Hinge Casting to Bottom Oilbox	SUNDRIES
289 Connecting Links to Long Link	148 Lower Pullout Chains
325 Dust Cover to Main Casting	229 Locking Wire for 280 & 280A
326 Dust Cover to Main Casting	261 Steel Balls for Thrust Washer
328 Balance Weights on Wheel	262 Steel Balls for Turntable
328A Balance Weight on Vane	263 Pull-out Chain from Vane
329 Roller Guide Casting to Rails	264 Wire for Oil Cup Lid Hinges
330 Chain Roller Bracket to Pullout Bracket (27/30')	265 Pull-out Wire Rope
LOOSE NUTS	266 Bearing Bush for Connecting Rod
211 Adjusting Screws for Vane (top)	267 Bearing Bush for Driving Shaft
212 Lock Nut for 209F	269 Mill Rods
213 Buffer Eye Bolt	272 Syphon Wicks for Oil Boxes – complete set
213A Nuts for Arms 67A & 68A (24')	273 Syphon Wicks – Roller Guide Oilbox
214 Nuts for 98	274 Syphon Wick for Conn. Rod
214A Nuts for 99	276 Split Link for Pullout Chain
SET SCREWS	277 Bushes for Crosshead
215 Oil Draining Plug	278 Ball Cage for Thrust Washer
216 Guide Roller Axle	309 Filling Plug – Mast Pipe Oil Well
216A Oil Level Set Screw	310 Draining Plug – Mast Pipe Oil Well
217 Thrust Collar	311 Brass Plug for Inner Collar Oilbox
218 Top Cover to H. W. Bearings	312 Wire Rope Clips for 265
219 Vane Hinge Rod Adjustor	312A Thimbles for 265
220 Roller Guide Spindle	315 Leather Washer for 215
220A Roller Guide Spindle Set Screws with Oil Hole	318 Stop for Mast Pipe (from 1960)
221 Inner Collar Locking Screw	324 Long Syphon Wicks for Crosshead Oil Tubes
319 Set Screws for 318 (from 1960)	327 Hook Bolts on Wheel Arms
SPLIT PINS	337 Leather Washer for Oil Level Plug
230 Oilbox Cover on Top Vane Hinge	338 Leather Washer between Hub and Main Casting
	339 Leather Washer for 310

POLYPRO COLUMN AND RODS

Now Available

ABOVE GROUND ASSEMBLY

UNDERGROUND ASSEMBLY

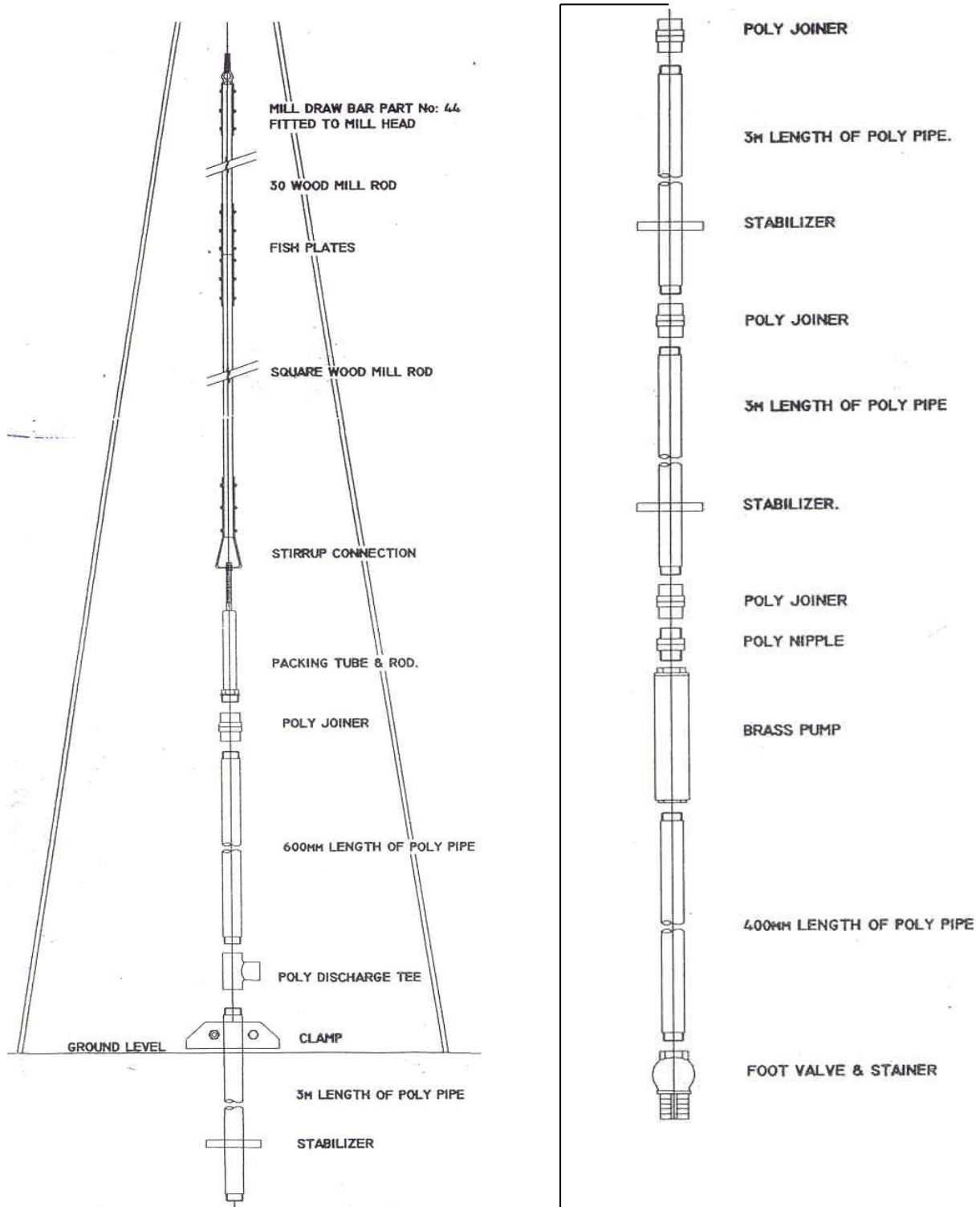

6/8 Ft Mills use 1½" delivery column and 1¼" Suction Pipe.
 10/12 Ft Mills use 2" delivery column and 1¼" Suction Pipe.
 14 Ft Mills use 2" delivery column and 1½" Suction Pipe.
 Hollow Polyrods are for 6/8 Ft Mills.
 Solid Steel reinforced rods are for 10/12/14 Ft Mills.
 Fittings vary in size to match up rods which are matched for length with columns.

WINDMILL PARTS

PULL ROD SPARE PARTS

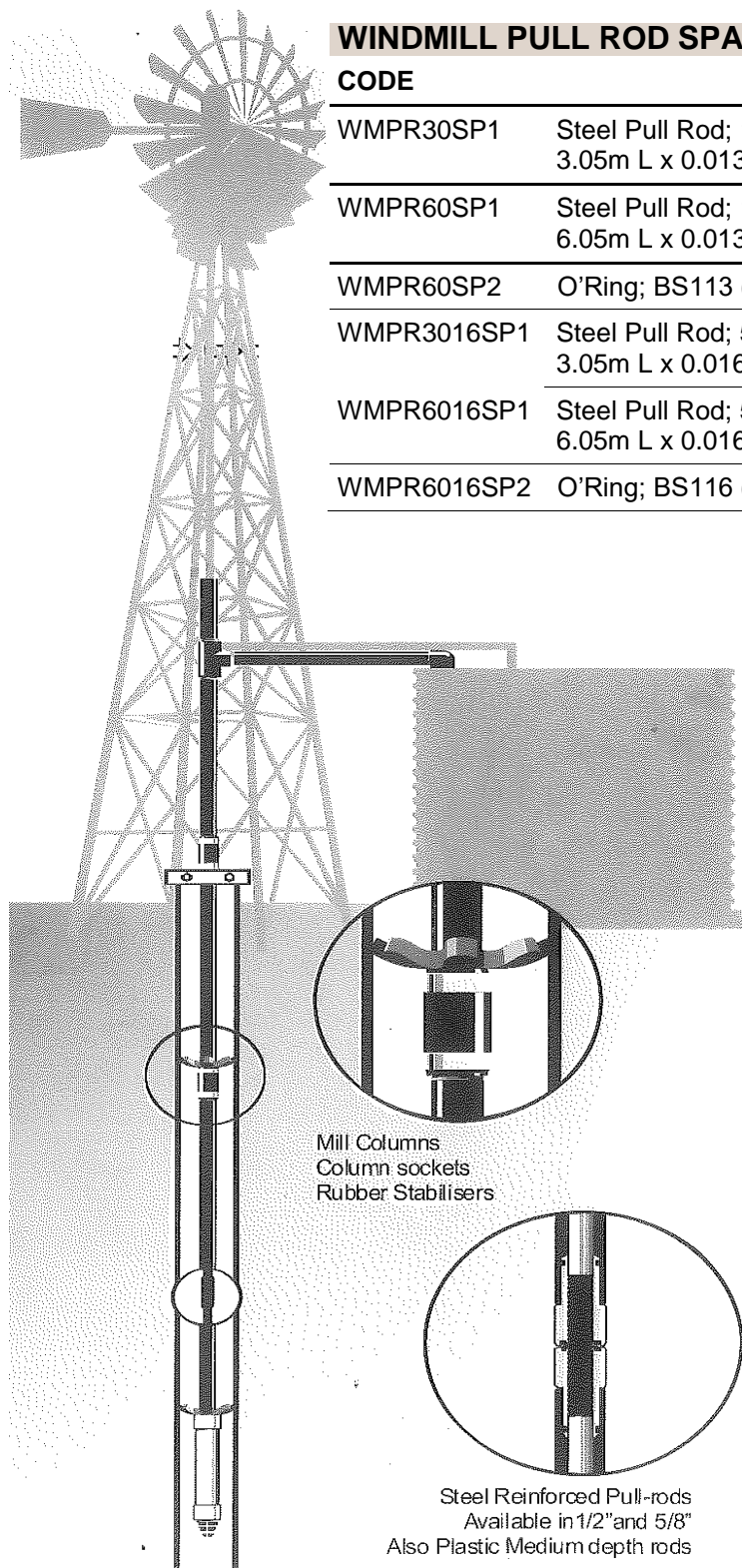

WINDMILL PULL ROD SPARE PARTS

CODE		WEIGHT	PRICE
WMPR30SP1	Steel Pull Rod; 12BSW MM; 3M 3.05m L x 0.013m OD	2.94kg	POA
WMPR60SP1	Steel Pull Rod; 12BSW MM; 6M 6.05m L x 0.013m OD	6kg	POA
WMPR60SP2	O'Ring; BS113 (For 12BSW; St'l RF-PP ROD)		POA
WMPR3016SP1	Steel Pull Rod; 58BSW MM; 3M 3.05m L x 0.016m OD		POA
WMPR6016SP1	Steel Pull Rod; 58BSW MM; 6M 6.05m L x 0.016m OD		POA
WMPR6016SP2	O'Ring; BS116 (For 58BSW; St'l RF-PP ROD)		POA

FEATURES

- Polpro System with non rusting pipe columns and pull-rods
- Replace old system with standard procedures
- Steel reinforced, compressed twin sealed, pull rods reduce loss of stroke
- Rubber stabiliser plates push onto Polpro mill column to centralise and steady the pipe
- Standard lengths and simple adaptors. Columns in BSP, Pull-rods in BSW threads
- Windmills operate quietly
- Pull-rod connections are long and slim to eliminate chaffing of the pump column
- Deep bore Pull-rods use brass sockets

WINDMILL COLUMNS

Polpro Heavy Duty Mill Pipe Columns

CODE		WEIGHT	PRICE
WM3204	Mill Column; PP; 32BSPM X 400mm 0.4m L x 0.043m OD	0.3kg	POA
WM3206	Mill Column; PP; 32BSPM X 600mm 0.6m L x 0.043m OD	0.4kg	POA
WM3212	Mill Column; PP; 32BSPM X 1200mm 1.2m L x 0.043m OD	0.7kg	POA
WM3230	Mill Column; PP; 32BSPM X 3000mm 3m L x 0.043m OD	1.6kg	POA
WM3260	Mill Column; PP; 32BSPM X 6000mm 6m L x 0.043m OD	3.2kg	POA
WM4004	Mill Column; PP; 40BSPM X 400mm 0.4m L x 0.049m OD	0.3kg	POA
WM4006	Mill Column; PP; 40BSPM X 600mm 0.6m L x 0.049m OD	0.5kg	POA
WM4012	Mill Column; PP; 40BSPM X 1200mm 1.2m L x 0.049m OD	0.9kg	POA
WM4030	Mill Column; PP; 40BSPM X 3000mm 3m L x 0.049m OD	2.1kg	POA
WM4060	Mill Column; PP; 40BSPM X 6000mm 6m L x 0.049m OD	4.2kg	POA
WM5004	Mill Column; PP; 50BSPM X 400mm 0.4m L x 0.061m OD	0.5kg	POA
WM5006	Mill Column; PP; 50BSPM X 600mm 0.6m L x 0.061m OD	0.8kg	POA
WM5012	Mill Column; PP; 50BSPM X 1200mm 1.2m L x 0.061m OD	1.5kg	POA
WM5030	Mill Column; PP; 50BSPM X 3000mm 3m L x 0.061m OD	3.8kg	POA
WM5060	Mill Column; PP; 50BSPM X 6000mm 6m L x 0.061m OD	7.1kg	POA
WM7530	Mill Column; PP; 75BSPM X 3000mm 3m L x 0.088m OD	8.5kg	POA
WM7560	Mill Column; PP; 75BSPM X 6000mm 6m L x 0.088m OD	16.9kg	POA

Columns Sockets to Suit Mill Pipe Columns

CODE		WEIGHT	PRICE
WMSS40	Column Socket; PP-SS; 40BSPF 0.14m L x 0.063m OD	0.27kg	POA
WMSS50	Column Socket; PP-SS; 50BSPF 0.14m L x 0.075m OD	0.33kg	POA
WMSS75S	Column Socket Short; SS; 75BSPF x 75mm 0.075m L x 0.1m OD		POA

Columns Stabiliser

CODE		WEIGHT	PRICE
WM15040	Mill Coll Stabiliser; Rubber 150mm—40BSP 0.15m Dia x 0.012m W	0.23kg	POA
WM15050	Mill Coll Stabiliser; Rubber 150mm—50BSP 0.5m Dia x 0.012m W	0.2kg	POA

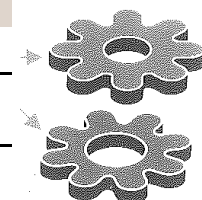
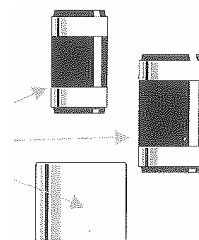
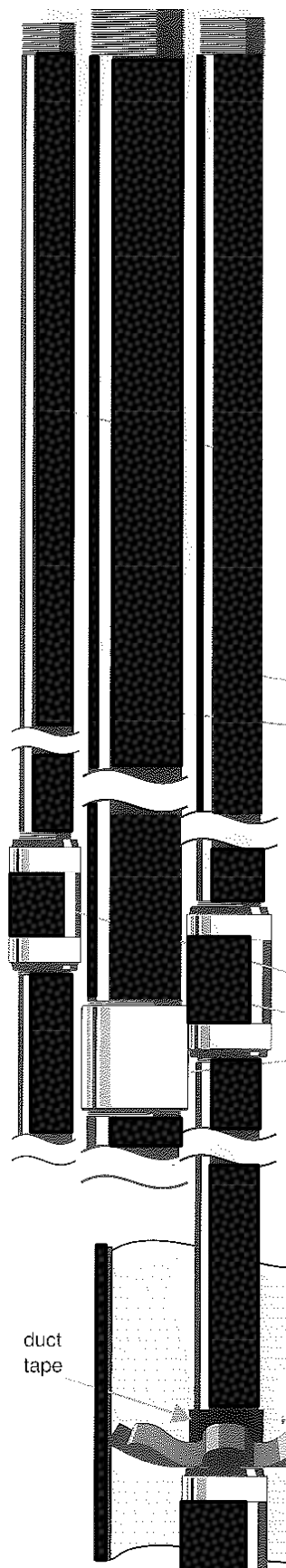

PULL RODS

Sectioned
View

Medium Depth Pull-Rods

CODE		WEIGHT	PRICE
WMPP30MD	Pull Rod; Med Depth– PP; 12BSW MF; x 3m 3m L x 0.027m OD	1.35kg	POA
WMPP60MD	Pull Rod; Med Depth– PP; 12BSW MF; x 6m 6m L x 0.027m OD	2.6kg	POA
WMPP3016MD	Pull Rod; Med Depth– PP; 5/8BSW MF; x 3m 3m L x 0.033m OD	2.2kg	POA
WMPP6016MD	Pull Rod; Med Depth– PP; 5/8BSW MF; x 6m 6m L x 0.033m OD	4.25KG	POA

**Pull-Rod
End with
BSW F**

Thick sectioned Polypropylene Pull-Rod suited to depth of 21m. Threaded internally to 1/2" or 5/8" BSW and with a long stainless steel threaded connecting rod in one end (M&F).

Sectioned
View

Heavy Duty Pull Rods

CODE		WEIGHT	PRICE
WMPR30	Pull Rod; Steel Reinf– PP; 12BSW MF; x 3m 3.05m L x 0.027m OD	4.35kg	POA
WMPR60	Pull Rod; Steel Reinf– PP; 12BSW MF; x 6m 6.05m L x 0.027m OD	8.49kg	POA
WMPR3016	Pull Rod; Steel Reinf– PP; 58BSW MF; x 3m 3.05m L x 0.034m OD		POA
WMPR6016	Pull Rod; Steel Reinf– PP; 12BSW MF; x 6m 6.05m L x 0.034m OD		POA

Heavily steel reinforced plastic sheathed pull-rod suited to depth of 60m. With brass threaded ends and o-ring seals. Provides a corrosion protected pull-rod (M&F).

**Pull-Rod
End with
BSWF**

Medium Depth Rod Adaptors

1/2" BSWM

CODE		WEIGHT	PRICE
WMA12M110	Pull Rod Adaptor; MD DTH; 12BSW MM x 110mm 0.11m L x 0.013m OD	0.09kg	POA
WMA16M130	Pull Rod Adaptor; MD DTH; 5/8BSW MM x 110mm 0.13m L x 0.016m OD	0.16kg	POA
WMA16B	Mill Rod Adaptor; Brass; 12BSWF x 58BSWF 0.055m L x 0.03m OD	0.19KG	POA

1/2" BSWF

5/8" BSWF

Adaptors for Medium Depth Pull-Rods. These adaptors provide rod conversions to 1/2" (12mm) BSW male or female thread and to 5/8" (16mm) BSW female thread.

Heavy Duty Rod Adaptors

1/2" BSWF

5/8" BSWF

CODE		WEIGHT	PRICE
WMA12M	Pull Rod Adaptor; SS; 12BSW MM x 50mm 0.05m L x 0.013m OD	0.04kg	POA
WMA16B	Mill Rod Adaptor; Brass; 12BSWF x 58BSWF 0.055m L x 0.03m OD	0.19kg	POA
WMA21B	Mill Rod Adaptor; Brass; 12BSWF x 12BSWF 0.055m L x 0.034m OD	0.13kg	POA
WMA58B	Mill Rod Adaptor; Brass; 58BSWF x 58BSWF 0.055m L x 0.025m OD	0.13kg	POA

1/2" BSWM

1/2" BSWM

Available in

MILL RODS & CONNECTIONS

Prices exclusive of GST and Freight

GALVANISED FISHPLATES WITH NUTS & BOLTS

CODE		PRICE
COM1214	No. 1 Galvanised Fishplates	\$ 19.50
COM1215	No. 1 Galvanised Fishplates	\$ 25.00
COM1216	No. 1 Galvanised Fishplates	\$ 26.50
COM1217	No. 1 Galvanised Fishplates	\$ 42.00

STIRRUP CONNECTION WITH NUTS & BOLTS

CODE		PRICE
COM1218	No. 1 38mm — 1½ x ½" Hole	\$ 58.00
COM1219	No. 1 38mm — 1½ x ⅝" Hole	\$ 66.00
COM1220	No. 2 50mm — 2 x ⅝" Hole	\$ 72.00
COM1221	No. 3 65mm — 2½ x ⅝" Hole	\$ 78.00
COM1222	No. 3 65mm — 2½ x ¾" Hole	\$ 94.00
COM1223	No. 4 75mm — 3 x ¾" Hole	\$ 122.00
COM1224	No. 4 75mm — 3 x ⅞" Hole	\$ 128.00

SCREWED PUMPROD COUPLINGS

CODE		PRICE
COM1225	½" Whitworth Brass Pumprod Coupling	\$ 16.00
COM1226	⅝" Whitworth Brass Pumprod Coupling	\$ 18.00
COM1227	¾" Whitworth Brass Pumprod Coupling	\$ 20.00
COM1228	1" Whitworth Brass Pumprod Coupling	\$ 23.00

KEEPER RINGS FOR BALL JOINTS

CODE		PRICE
COM1229	1" Whitworth Brass Pumprod Coupling	\$ 23.00
COM1370	No. 2 Steel Keeper Ring	\$ POA
COM1370	No. 3 ⅝" Brass Pumprod Coupling	\$ 18.00
COM1371	No. 4 ⅝" Brass Pumprod Coupling	\$ 20.00
COM1372	No. 4 ¾" Brass Pumprod Coupling	\$ 20.00
COM1373	No. 2 ⅝" Brass Pumprod Coupling	\$ 25.00
COM1374	No. 3 1" Brass Keeper Ring	\$ 28.00
COM1375	No. 4 ⅞" Brass Pumprod Coupling	\$ 29.00
COM1376	No. 4 1" Brass Pumprod Coupling	\$ 28.00
COM1237	⅞" x 1" Brass Pumprod Coupling	\$ 38.00



PUMPRODS, JOINTS & CONNECTIONS

STEEL PUMPRODS

Prices quoted are exclusive of GST and Freight.

SOLID STEEL PUMPRODS WITH STEEL BALL JOINTS -BLACK OR GALV.

CODE	DESCRIPTION	SIZE	PRICE ex GST
COM1269	16mm Dia.X 6.5m Mild Steel Pumprod with No 2 Steel Ball Joints	5/8"	\$164.00
COM1271	20mm Dia.X 6.0m Mild Steel Pumprod with No 3 Steel Ball Joints	3/4"	\$194.00
COM1273	25mm Dia.X 6.0m Mild Steel Pumprod with No 4 Steel Ball Joints	1"	\$217.00

GALVANISED STEEL TUBE PUMPRODS WITH STEEL BALL JOINTS

CODE	DESCRIPTION	SIZE	PRICE
COM1281	12mm Dia.X 6.5m Galv. Mild Steel Pumprod / No 2 Steel Ball Joints	1/2"	\$154.00
COM1283	20mm Dia.X 6.5m Galv. Mild Steel Pumprod / No 3 Steel Ball Joints	3/4"	\$172.00
COM1285	25mm Dia.X 6.5m Galv. Mild Steel Pumprod / No 4 Steel Ball Joints	1"	\$196.00

HARDWOOD PUMPRODS WITH STEEL BALL JOINTS

CODE	DESCRIPTION	SIZE	PRICE
COM1248	45mm x 25mm x 6.5m Hardwood Pumprod / No 2 Steel Ball Joints	1 3/4" x 1"	\$174.00
COM1250	45mm x 32mm x 6.5m Hardwood Pumprod / No 3 Steel Ball Joints	1 3/4" x 1 1/4"	\$196.00
COM1252	50mm x 40mm x 6.5m Hardwood Pumprod / No 4 Steel Ball Joints	2 x 1 1/2"	\$221.00
COM1254	65mm x 40mm x 6.5m Hardwood Pumprod / No 4 HD Steel Ball Jnts	2 1/2" x 1 1/2"	\$246.00

HARDWOOD PUMPRODS WITH BRONZE BALL JOINTS

CODE	DESCRIPTION	SIZE	PRICE
COM1256	45mm x 25mm x 6.5m Hardwood Pumprod / No 2 Bronze Ball Joints	1 3/4" x 1"	\$ 280.00
COM1258	45mm x 32mm x 6.5m Hardwood Pumprod / No 3 Bronze Ball Joints	1 3/4" x 1 1/4"	\$ 310.00
COM1260	50mm x 40mm x 6.5m Hardwood Pumprod / No 4 Bronze Ball Joints	2 x 1 1/2"	\$ 340.00
COM1262	65mm x 40mm x 6.5m Hardwood Pumprod / No 4 HD Bronze Ball Jnts	2 1/2" x 1 1/2"	\$ 350.00



PUMPRODS, JOINTS & CONNECTIONS

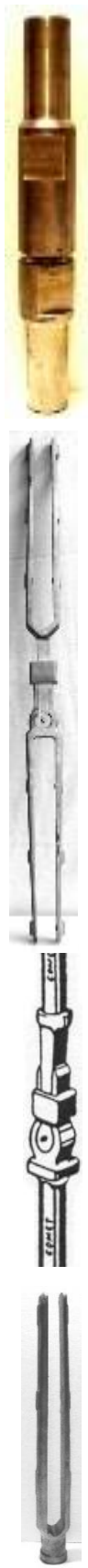

BOX AND PIN JOINTS FOR PIPE PUMPRODS		EX GST
COM1350	No.4 Box and Pin Screwed Joint (Weld On)	POA
COM1351	No.4 HD Box and Pin Screwed Joint (Weld On)	POA
BOX AND PIN PLUNGER ROD CONNECTIONS		
COM1354	No.4 Box and Pin Plunger Rod Connection 7/8" Whit.Shank	POA
COM1355	No.4 Box and Pin Plunger Rod Connection 1" Whit.Shank	POA
BOX AND PIN PUMPROD TOP END CONNECTIONS		
COM1359	No.3 Box and Pin Top End Connection 1" Whit.Shank	POA
COM1360	No.4 Box and Pin Top End Connection 1" Whit.Shank	POA
STEEL BALL JOINTS FOR WOOD PUMPROD		
COM1310	No 2 Steel Ball Joint with Galvanised Rivets	\$ 160.00
COM1311	No 3 Steel Ball Joint with Galvanised Rivets	\$ 180.00
COM1312	No 4 Steel Ball Joint with Galvanised Rivets	\$ 210.00
COM1313	No 4 HD Steel Ball Joint with Galvanised Rivets	\$ 220.00
BRONZE BALL JOINTS FOR WOOD PUMPROD		
COM1314	No 2 Bronze Ball Joint with Copper Rivets	\$ 210.00
COM1315	No 3 Bronze Ball Joint with Copper Rivets	\$ 240.00
COM1316	No 4 Bronze Ball Joint with Copper Rivets	\$ 280.00
COM1317	No 4 HD Bronze Ball Joint with Copper Rivets	\$ 310.00
STEEL BALL JOINTS FOR STEEL PUMPRODS		
COM1318	No 2 Steel Ball Joint (Weld On) Solid (bar)	\$ 120.00
COM1319	No 3 Steel Ball Joint (Weld On) Solid (bar)	\$ 140.00
COM1320	No 4 Steel Ball Joint (Weld On) Solid (bar)	\$ 160.00
STEEL BALL JOINTS FOR STEEL PUMPRODS		
COM1321	No 2 Steel Ball Joint (Weld On) Pipe	\$ 120.00
COM1322	No 3 Steel Ball Joint (Weld On) Pipe	\$ 140.00
COM1323	No 4 Steel Ball Joint (Weld On) Pipe	\$ 160.00
COM1324	No 4 HD Steel Ball Joint (Weld On) Pipe	\$ 180.00
BRONZE FORK CONNECTIONS		
COM1325	No 2 Bronze Fork Connection Tapped 5/8" Whit.	\$ 200.00
COM1326	No 2 Bronze Fork Connection Tapped 3/4" Whit.	\$ 210.00
COM1327	No 3 Bronze Fork Connection Tapped 3/4" Whit.	\$ 220.00
COM1328	No 3 Bronze Fork Connection Tapped 7/8" Whit.	\$ 240.00
COM1329	No 4 Bronze Fork Connection Tapped 7/8" Whit.	\$ 280.00
COM1330	No 4 Bronze Fork Connection Tapped 1" Whit.	\$ 290.00

PIPE AND CASING CLAMPS



CODE DESCRIPTION

COMBINED PIPE & CASING CLAMP

		Size <i>Inch</i>	PRICE <i>ex GST</i>
COM1450	125mm x 32mm Combined Pipe & Casing Clamps	5 x 1¼"	\$ 280.00
COM1451	125mm x 40mm Combined Pipe & Casing Clamps	5 x 1½"	\$ 290.00
COM1452	125mm x 50mm Combined Pipe & Casing Clamps	5 x 2"	\$ 280.00
COM1453	125mm x 65mm Combined Pipe & Casing Clamps	5 x 2½"	\$ 290.00
COM1454	125mm x 80mm Combined Pipe & Casing Clamps	5 x 3"	\$ 290.00
COM1455	150mm x 32mm Combined Pipe & Casing Clamps	6 x 1¼"	\$ 300.00
COM1456	150mm x 40mm Combined Pipe & Casing Clamps	6 x 1½"	\$ 300.00
COM1457	150mm x 50mm Combined Pipe & Casing Clamps	6 x 2"	\$ 300.00
COM1458	150mm x 65mm Combined Pipe & Casing Clamps	6 x 2½"	\$ 300.00
COM1459	150mm x 80mm Combined Pipe & Casing Clamps	6 x 3"	\$ 300.00

The two larger castings of this 3-piece clamp are rested on and clamped to the top of the bore casing and the column pipe is then centrally clamped in the upper portion. Thus the bore is almost completely covered. The sizes for 5 or 6" casing take 1¼, 1½, 2, 2½ and 3" pipe.

HEAVY PIPE CLAMP (Max. Load 150M)

Cast Iron and Steel



COM1460	50mm Heavy Pipe Clamp	2"	\$ 260.00
COM1461	65mm Heavy Pipe Clamp	2½"	\$ 270.00
COM1462	80mm Heavy Pipe Clamp	3"	\$ 280.00

These exceptionally strong clamps are made in three sizes for 2, 2½ and 3" pipe. The cast iron gripping blocks are bored and grooved to provide a maximum hold on the pipe and are supported by two pieces of heavy angle steel. The angles are provided with holes for attaching to a foundation if necessary.

CAST STEEL PIPE OR CASING CLAMP



COM1463	90mm Cast Steel Pipe Clamp	3½"	\$ 230.00
COM1464	100mm Cast Steel Pipe Clamp	4"	\$ 270.00
COM1465	125mm Cast Steel Pipe Clamp	5"	\$ 290.00
COM1466	150mm Cast Steel Pipe Clamp	6"	\$ 350.00

These ribbed Cast Steel Clamps have the advantage of great strength with lightness, and are particularly suitable for supporting long pipe or casing pump delivery columns. The internal annular bearing strips are ground to fit the column and provide an exceptional non-slip grip. Made for 3½" pipe, 4, 5 and 6" casing.



COMET BORE PUMP BOOSTER

More water can be pumped from new or old bores by the use of our Comet Bore Pump Booster. The Booster seals off the top of a bore, allowing a partial vacuum to be created within the casing. The result is an increase of up to 33% in the capacities of bore and pump. Made in sizes to fit 4, 5 and 6 inch casing. POA.

CONTACT DETAILS:

COMET WINDMILLS AUSTRALIA PTY LTD
PO BOX 340
MACKSVILLE NSW 2447

PH: 02 6568 3711

FAX: 02 6568 3722

email: sales@cometwindmills.com.au

web: www.cometwindmills.com.au



*The Comet Windmill,
an icon of inland Australia.*

Windmills are scattered all over the Australian continent like tireless sentinels standing guard over precious water supplies that give and sustain life. The Comet is a fitting symbol of the Australian Outback - representing perseverance and sustainability in a harsh environment, a sense of timelessness, and the contribution to the Outback that remains superior....that is why Comet is still....Australia's Leading Mill.

